



BRCA

BRITISH RADIO CAR ASSOCIATION

www.brca.org

LARGE SCALE OFF-ROAD



Handbook 2019

elite racing

OFFICIAL UK DISCRIBUCOR FOR SERPENT ONROAD CARS



16%
DISCOUNT
ON ALL
FUEL

elite power
RACING FUEL

Distributed by ELITE RC RACING
www.elitec-online.co.uk

01422 373010
sales@elitec-online.co.uk

Also Available in 25%



SERPENT
RACING TEAM

contact
RC RACING TYRES



Email sales@elitec-online.co.uk Tel 01422 373010

www.eliterc-online.co.uk

CONTENTS

How To Use This Handbook	5
Chairman's Introduction	6
Committee & Contacts	8
LSOR A Beginners Guide	10
2019 Calendar	15
How To Enter Our National Events	16
Specialist Retailers	17
How To Find Your Local Club	17
Round 1 - Nene Valley Raceway	18
Round 2 - Ebberston RC Track	20
Round 3 - Lincolnshire Radio CCC	22
Round 4 - Pickering Raceway	24
Round 5 - MMR Raceway	28
Round 6 - Pickering Raceway	30
Round 7 - Lincolnshire Radio CCC	32
Round 8 - Nene Valley Raceway	34
Procedural Rules	37
Construction Rules	47
Guidelines For Referees	51
Setup Sheets	52



rc-car-online.de

hpi-racing

HiTEC

MULTIPLEX

ZENOAH

BubbleEX

ROADIES

CARSON
MODEL SPORT

FD Racing

Mecatex

LightScale

TRACERACING

HP Creations

UMC

TRACERACING

LOCTITE

SANWA
THE 2.40Hz SPECIALISTS

ELITE

Smartech

SPECTRUM

SPEED
TECH

PANOLIN +

JET PRO

SAMBA

SCS M2
High Performance Parts and Tools

TOUREX

MadMax

OKS

Energy Pump

BINDULIN

HORIZON

MAGIC RAIN

MOTUL

DHL FedEx
Spare and Tuning part fast delivery service

For over
40 years



Congratulations to our
colleague Günter Honert to
winning the Championships



Shop hours:

Mo. - Fr. 9 - 18 , Sa. 9 - 13 o'clock.

On 1,000 m² more than 1,000 cars and
more than 10,000 spare / option parts.



Available on the
App Store

ANDROID APP ON
Google play



rc.car.shop

RC-MAPS
Powered by rc-car-online.de

**RC PLACES
NEAR TO YOU!**



To the Shop

rc-car-shop Hobbytek

Nauenweg 55 - D- 47805 Krefeld - Phone: +49 02151/820200

E-Mail: hobbytek@t-online.de - www.rc-car-online.de

RC
TECH

MEGA

WALERC

LSI

1/18

T2M

F

HARM
RACING

TLR
TEAM LOSI RACING

CYS

HOW TO USE THIS HANDBOOK

This handbook is aimed at competitors, officials of for the Large Scale Off Road section and those interested in our national series, enabling all to have the information required for the national series at all times. However, it should prove useful to all club racers too, as we hope it will give the reader more information about our national series.

The information contained herein should be read in conjunction with the Association Handbook as the General Rules contained in the handbook apply to us all, at all events, and in any circumstances, take precedent over sectional rules. It is every member's responsibility to ensure they have read and understand the general rules (ask an executive official, as appropriate, for clarification if you don't).

The application of the rules works thus:

The Association General Rules apply at all events we go to, including most club racing as we are all members of the association at all times. Section rules (as in this book) apply at Nationals plus other events, e.g. regional's, as sanctioned by the section committee. Section rules do not apply at clubs, unless the clubs wish them to and it is entirely the club's choice either way.

Changing a rule

Every rule in this booklet and the Association Handbook was proposed and voted in by one of your fellow racers - none of the committees can simply 'make up' a rule. If you don't like a rule you can easily try and have it changed (though the first thought should be to find out the rationale of why one of your fellow racers proposed it in the first place perhaps?). If you think a rule needs changing get somebody else to agree with you - a seconder - and then write/email to one of the following people:

Section Rule to be changed - Section Secretary, who will liaise with you to ensure it's then voted on at their section conference.

Association General Rule including the Constitution - Association Secretary, who will liaise with you to ensure it's voted upon at the Association annual general meeting. You should endeavour to be at any meeting where a rule change you have proposed is taking place as it will be discussed, possibly amended, plus you'll almost certainly be asked to elaborate on it.

Summary

'The Rules' should be the easy bit of our sport, but they're not as we're all passionate about our sport and should want to have an input into how it's run, so make sure you have your say. The Association works because people get involved and make a difference.

If you don't like how something is being done, you should offer to do it yourself. Every Association official is a volunteer and they are doing a role because it needs doing. However, it is as much your responsibility to do that task as it is theirs - it's just that they volunteered to do it before you had the opportunity to offer to do it better.

BRCA Large Scale Off-Road Section
Handbook 2019
© BRCA 2016-2019
All rights reserved

Registered address:
BRCA c/o, 7 Buck Lane,
Hough, Crewe
Cheshire, CW2 5JP

The BRCA's consent must be obtained before any part of this publication may be reproduced in any form whatsoever, including photocopyers and information retrieval systems.

CHAIRMAN'S INTRODUCTION

Welcome to your new 2019 Large Scale Off Road (LSOR) handbook.

This class of racing is probably one of the youngest in the association, LSOR racing started around 2000 with grown men standing in a field and running FG Marders. Unlike other classes our buggies do not represent any specific model or brand, whereas the short course vehicles which were introduced in 2012 represent the large US stadium trucks which race in the Lucas Oil Off Road Racing Series. Whilst we are known as the LSOR section our scale is a mix of 1:5 and 1:6 if there was anything we could be measured against. We are the largest form of off road radio controlled racing in the UK and the world.

LSOR cars are miniature versions of what you may see off road racing, with some complex engineering but simple to work with features you would find on your road car with all vehicles built on a metal chassis with either plastic or alloy body parts. Power is provided by a petrol engine which gives them their incredible speed and acceleration. That said, the cars are typically straightforward to drive at a basic level and are traditionally quite easy to get the hang of quickly. With running off road, and the relative simplicity of an LSOR chassis ensures that this is a competition that not only rewards the driver's skill, consistency but also the ability to understand car setup. The result of many national races is regularly decided by fractions of a second.



Unlike other classes raced within the association, Large Scale races can run for 30 minutes without any refueling. This increased track time for your money, combined with the relatively low cost of running LSOR cars has to be one of the major advantages of this class.

LSOR can be undertaken all year round and there is likely to be a club near you which supports the class that not only runs meetings over the summer months but also winter ones too. Together with host clubs we also run professional, friendly and well organised national competitions that welcome drivers of all abilities. Our national series runs over a weekend from March to October, so whatever the weather you can guarantee that the LSOR race will continue.



Most of our national championship venues try and provide hot and cold food and drinks, while all events provide space for pitting and camping for those who wish to stay at the venue. Further venue details can be found later in this handbook.

The purpose of the national championship is to provide as uniform as possible a format for large scale off road RC cars, to be able to compete with one another on an open National basis. The intention is to encompass all driver abilities and



commercially available large scale off road vehicles, yet still encourage invention and innovation by allowing "one off" home constructed cars and modification of kit products

Entry to national events is done via the BRCA website in the Large Scale area, where you will also find detailed rules and regulations and other useful information. This is also where updates and results will be posted throughout the year. There is more information relating to this contained in this document.

I started my involvement in LSOR in 2005. Back then you'd have been lucky to see 25 competitors at a national championship event and it was seen as very much a 'niche' or 'specialist' class. Things have changed and developed over the years since and it is not uncommon to now see as many as 80 competitors at a national event, which has coincided with an increase in LSOR friendly clubs around the country.

This has been thanks in no small part to the will and enthusiasm of club and BRCA officials and also of our competitors, who have countless years of experience and a vast knowledge base to share with newcomers. We like to think of ourselves as a friendly class of RC racing in which you can choose to compete at any level.

Our aim is to organise the biggest and best Large Scale Off Road National Championship in the world whilst giving good value for money and supporting the class at grass roots level. We hope that you will choose to become a part of what we do and come and race with us.

In 2017 the section hosted the LSOR European Championship which saw 130 racers travel from 15 countries competing for the class titles. It was a pleasure to host such an event and see the UK team

compete with the best drivers in Europe. In 2018 a UK Team of 18 traveled to Austria and raced with the best, in 2019 Team UK will head to Bulgaria, good luck all.

Good luck with your racing during the forthcoming season no matter if it's club level, national level or international level. A big thank you to the traders who have taken up advertising space within this handbook.



Darren Worth

Chairman, BRCA Large Scale Off Road Section

COMMITTEE & CONTACTS



DARREN WORTH

Chairman

Isorchair@brca.org

07976 267385



DARREN WORTH

Webmaster

Isorweb@brca.org

07976 267385



PETER BARNES

Secretary

Isorsec@brca.org

07921 651008



DANE WHITTLESTON

Treasurer

Isortreasurer@brca.org

07985 250578



HEIDI SHILCOCK

Media Officer

Isormedia@brca.org

07889 788878



CRAIG ORMAN

LS EFRA Rep

Isorefra@brca.org

07787 360205



PAUL GRESTY

Safety Officer

Isorsafety@brca.org

07837 7923095



PHIL CHESTER

Head Scrutineer

Isorscrut@brca.org

07487 7770530



PAUL KEATLEY

Head Referee

Isorref@brca.org

07973 264863



DANE WHITTLESTON

Vice Chairman

Isorvice@brca.org

07985 250578



STEVE JONES

Referee

Isorref1@brca.org
07929 307689



EWA JONES

Referee

Isorref2@brca.org
07929 307689



MATT BUXTON

Referee

Isorref3@brca.org
07826 646564



JOHN HALL

Referee

Isorref4@brca.org
07754 746968



ANDREW KNIGHT

Scrutineer

Isorscrutu1@brca.org
07762 343162



RICHARD FALLOWFIELD

Scrutineer

Isorscrut3@brca.org
07876 450166



IAN SOUTHEY

Scrutineer

Isorscrut4@brca.org
07825 272156

PLEASE DO NOT

HESITATE TO

CONTACT US

DIRECTLY IF WE

CAN BE OF ANY

ASSISTANCE

LSOR A Beginners Guide

Taking up a brand-new hobby is a somewhat daunting prospect for someone of any age or background. There's a lot to learn and take on board, often before you've really started out properly. RC car racing is no different, and in fact nearly always it will be of benefit to do some reading and find out the basics before committing to a purchase or making a decision.

This article assumes that you've already decided that RC racing is for you and that you're considering LSOR as the class to start off with, or maybe you've previously raced another class such as nitro on road or electric buggies and are coming in to LSOR for the first time.

The short checklist below outlines the milestones that you'll need to reach in order to go from 'having an interest' to 'going racing' in LSOR:

- Become a BRCA Member
- Find your nearest club that supports the LSOR class
- Purchase the equipment you need
- Build/prepare your car and go racing
- Take your racing to the next level



Become a BRCA member

BRCA membership is important and should be the first thing to cross off your 'to do list'. For more information about what BRCA membership provides and why it is important, visit the BRCA website at www.brca.org. You can also use this link to join the BRCA online.

Find your nearest club

LSOR cars are designed specifically for racing, which means they aren't suitable for driving up and down the street or in a local car park. Therefore, it is strongly advisable to find out where your nearest club is that supports LSOR racing and pay them a visit.

Finding your nearest club will not only allow you to establish where you will be able to race your LSOR car, but also to start getting that thing which money can't buy: good advice! On your first visit to the club, ask the racers about their LSOR cars and the racing. What equipment do they use? How much does it cost and where do they buy it from? Are there any rules specific to the club that you need to be aware of? Establishing these things will lay the foundations for what comes next, give you a much better understanding of what LSOR racing entails and hopefully enable you to make informed decisions on what to buy.





Purchase the equipment you need

LSOR cars come in kit form and typically include the main chassis and suspension components along with a detailed assembly manual.

There are lots to choose from and most of the major manufacturers make a competitive car. The simplistic nature of LSOR cars means that pretty much all of the leading brand cars could be winners in the right hands. It usually comes down to how you build, setup and drive the car rather than one chassis having an advantage over another. Choose a car that seems to be popular and has good backup for spare parts and advice.

In addition to a chassis kit you'll need a full set of electrics including radio gear. It is typically a good idea to choose a radio system which has adjustable features such as steering end points and throttle and brake curves. Whilst a little more expensive these tend to be of better quality, have a faster response and will help you get the most out of your LSOR car.

LSOR cars are powered by a petrol engine of anywhere between 23cc and 30cc depending upon the class raced. People start out with a standard manufactures engine and then move towards one of the "tuned racers" engines to suit your driving style. Coupled to the engine is the clutch and drive gears on one side and on the other side is a suitable exhaust which complies with our noise limits.

Whilst the LSOR cars are powered by a petrol powered engine you will still need a suitable battery to power the vehicles radio and electrical system. This battery can be anything from a standard cell pack of non-rechargeable batteries, or suitable rechargeable versions up to HARDCASED LiPo \ LiFe batteries which are compliant to our safety rules. Now the vehicle is able to run you will now need a method of stopping it, and this all depends upon the vehicle. The short course trucks comes standard with a lay shaft central diff brake, likewise so do some 4 wheel drive buggies, whilst others still use a lay shaft brake but direct on the rear wheels. Additional brakes can be fitted to each corner of your ride by adding piston activated pads and shoes just like a real car feed by hydraulic fluid or developed over recent seasons an alternative using air and bellows to bring the shoes and pads together.

You'll also need a servo to provide the steering on your car. There are several to choose from and they are of varying prices and quality. LSOR cars use the larger sized servos than other RC cars so make sure that the servo you purchase is compatible with your chassis.

What good is a car if it's got no wheels? LSOR cars use rubber tyres with foam inserts and there are plenty available from different manufacturers in a range of compounds. The best advice we can give in this area is speak with your local club racers and choose a tyre brand that you're comfortable with. Different manufacturer's wheels can have different offsets, so make sure you get the right ones for your vehicle to ensure it complies with our width requirements. LSOR tyre compounds are usually classified as Soft, Medium or Hard with the most widely used being manufactured by MCD, Hormann and Schumacher. If you're unsure of what brand and which compounds to buy, ask for help.

Unlike other scales LSOR racers suffer from a lack of bodyshells so you normally end up with your chassis manufacturers bodyshell on your ride, year after year but at least they are all painted differently if you so wish!

Finally, you'll need equipment to charge your batteries, an associated charging sack, your race fuel and oil and a set of tools to use when working on your car. Also don't forget suitable footwear, gloves and to bring your hi-viz tabard too when you come racing as all drivers and marshals must wear one when trackside. As with the other items above, seek advice online or at your local shop or club regarding what to buy.

Build your car and go racing

The most important thing here is to TAKE YOUR TIME. LSOR cars despite their size they are very sensitive, so try to be thorough when you build and prepare the car. Make sure all of the moving parts do so freely and try to avoid wires catching on the inside of the bodyshell. Time spent in properly preparing your car will pay dividends in the long term and you'll be able to get the most out of your chassis. There's a wealth of information available online and the drivers at your local club will be happy to help too; just ask them for advice on what they do.

By this time, you should already have found your nearest club and have a good idea of how they operate. Take things slow and steady to begin with; concentrate on driving smoothly and consistently and the speed will build as you get more comfortable.

Take your racing to the next level

Once you've been racing at club level for a while you may find that you want to go and experience different tracks and meet new people. This is one of the great things about LSOR and RC car racing in general; there's a vast network of people, clubs and events to engage with, whatever your level of ability and experience.

It may seem daunting, but actually one of the best ways to learn about LSOR is to enter a national championship event. These events are open to anyone and there is sure to be someone else competing at your level. What's more, you'll have direct access to help and advice from the country's fastest and most experienced drivers. It is probable that you'll learn more in a single national weekend than during several months of club racing as in many cases you'll be able to pick up and understand the do's and don'ts from other people instead of having to figure them out for yourself. There is more information about this year's national events in this handbook.

Your next race may be overseas

Racing in European championships is one of the biggest and best experiences an RC enthusiast can be a part of. From playing in the garden and the park, through to club racing and onto the national championship level, is a steady progression which includes a great deal of learning, practice and dedication. Once you're at the stage you feel you're ready to progress, there are plenty of very popular international Invitational meetings that people can race at to get the feel of racing abroad. These are usually very well attended with a good number of the biggest manufacturers and top drivers. These meetings are a great stepping stone to the European championships.





The European championships is a whole other level. No matter where these events are held you can expect to see all the top manufacturers, and top drivers from 15 or more countries. You will experience racing at the highest level with the best facilities and everything running like clockwork - all this goes hand in hand. Everyone is so approachable even with the language barriers, there will always be someone to lend a hand or offer help.

Not only will you have different cultures and languages, you'll also have a great variety of food and drink to sample - a particularly enjoyable part of the trip for me. Whether you travel alone or as a group, the trip to the venue is all part of the experience and well worth the effort.

As part of a team representing your country, it's a proud moment to walk out on the track as part of the opening ceremony. Wearing the team shirt and with the national anthem playing in the background it's a great feeling to be involved.

During the Euro's there is plenty of time to make changes to your car and even relax between races. Monday morning is when the action on the track starts with practice through until Wednesday which is timed practice. Wednesday is also the opening ceremony with the procession and opening party. Heats start on Thursday and lead into Friday - with sub final on the Friday afternoon. Saturday is the day that every is racer aiming for. With 1/4, 1/2 and A finals in each class it's a busy day. The trophy presentation is a big part of the championship with the top 10 in each class getting a trophy along with the highest junior. All this and the chance of getting on television with the EFRA media partner RCRacing.tv.

2017 was a special year for the BRCA LSOR section, we hosted the European LSOR Championship at the Nene Valley Raceway Facility in Northamptonshire and had a team of over 45 drivers entered. The UK managed to have drivers in all three class finals, who knows at future events it maybe you the UK team are cheering on.

The journey begins here

All that remains is for us to wish you the best as you embark upon racing LSOR. We hope that you enjoy it and that in doing so you remember these key bits of advice:

- Take your time
- Ask for help if you're unsure
- Practice as much as you can

See you trackside soon!





RCMODELZ.CO.UK

THE UK'S LARGEST
1/5TH SCALE RC
STOCKIST

30 DEGREE NORTH TRUCK
4WD RTR
£699.99*



*prices are correct at the time of printing, subject to change without notice

KM 10th ANNIVERSARY
EDITION
£574.99*



*prices are correct at the time of printing, subject to change without notice



5% OFF WITH CODE
redeemable at www.rcmodelz.co.uk terms and conditions apply

RCMZ

@RCMODELZ @RCRACING f /RCRACING

E-mail : sales@rcmodelz.co.uk - www.rcmodelz.co.uk

PROUD
STOCKIST
OF



FID RACING

MadMax
SPECIAL PARTS

1/5
1/6
1/8
1/10
1/12
1/18
1/24
1/36
1/48
1/60
1/72
1/84
1/96
1/108
1/120
1/144
1/168
1/180
1/192
1/216
1/240
1/252
1/270
1/288
1/300
1/324
1/360
1/400
1/420
1/432
1/450
1/480
1/504
1/540
1/560
1/576
1/600
1/630
1/648
1/672
1/700
1/720
1/756
1/792
1/800
1/810
1/840
1/864
1/880
1/900
1/936
1/960
1/972
1/1000

ARCA

OL
Racing

ATOP

EMCD
Racing

IS Performance

ROVAN™

ZENORH

SAMBA

BoosterPics

UberRC

SAVOX

HITEC

K-power



hpi-racing

OVERLANDER

ABSIMA

Futaba

FACTORY
Team

TRAXXAS

BONDLOC
FORMULAS THAT WORK



2019 CALENDAR

BRCA LARGE SCALE OFF-ROAD NATIONAL CHAMPIONSHIP WEEKENDS

	Date	Event	Venue
March	30 th - 31 st	LSOR National Round 1	Nene Valley Raceway, Northamptonshire
April	20 th - 21 st	LSOR National Round 2	Ebberston RC Track, Yorkshire
May	24 th - 25 th	LSOR National Round 3	Lincolnshire Radio CCC
June	15 th - 16 th	LSOR National Round 4	Pickering RC Track, Yorkshire
July	6 th - 7 th	LSOR National Round 5	MMR Raceway, Wiltshire
August	17 th - 18 th	LSOR National Round 6	Pickering RC Track, Yorkshire
September	14 th - 15 th	LSOR National Round 7	Lincolnshire Radio CCC
October	12 th - 13 th	LSOR National Round 8	Nene Valley Raceway, Northamptonshire



HOW TO ENTER OUR NATIONAL EVENTS

Each year clubs from all over the country are invited to submit applications to host a round of our national championship. The committee strive to make every national competition the best possible series of events, providing quality tracks and facilities to give drivers value for money.

Each day in the national series is an individual standalone event meaning you can enter as little as a single days racing if you've never tried one of our competitions before.

All entry is done via the BRCA & BRCA LSOR websites.

- Go to www.brca.org/lso-events
- As you scroll down you will see a list of the available events.
- If your expected event is not shown then online booking is closed, booking in closes the Wednesday before our event. Payment can still be made online until the night before our event or trackside with your card
- Simply click on the Enter button next to the event you wish to enter to add this to your cart.
- You can then either click checkout to go on and complete your entry or add more events to add more entries to your cart.
- You will need to log into your BRCA account to complete race entry. If you are not currently registered then you will need to complete the online registration process via the Join option shown on the webpage.
- You will then be redirected to a PayPal payment page to complete your entry.

Over the next series of pages you will find details of the events for the current season.



SPECIALIST RETAILERS

There are a number of specialty retailers who can offer a ready source of advice together with supplying everything you could ever need to go racing.

Hobbythek	rc-car-online.de	Kingcobra	www.kingcobra.co.uk
PG Racing	www.pgracing.co.uk	Rcmodelz	www.rcmodelz.co.uk



*For all your Hormann and
general Largescale spares*

PGRacing.co.uk

*Call Paul on 07837 923095 or
email sales@pgracing.co.uk*

*PGRacing can be found
trackside at all LSOR events*



HÖRMANN
TUNING

www.hoermann-modelltechnik.de

HT3 V2

HOW TO FIND YOUR LOCAL CLUB



A database of clubs
can be found on
the BRCA website at:
www.brca.org/clubs

NENE VALLEY RACEWAY

Address

Nene Valley Raceway, Airfield Road, Podington,
Wellingborough, Northamptonshire, NN29 7XA

Track

Astroturf

Size

70m x 40m,
400m in length

Markers

Black marine rope, rubber
corner boards

Rostrum

40ft covered rostrum with
single stair access

Pits

Astroturf area with 240V
power at a nominal
meeting fee

Toilets

Ladies, Gents

Access

Disabled access to track
and pits

Catering

Onsite catering.
Supermarkets, hotels and
takeaways local



Setup Sheet

Name: _____	Event: _____	Track: _____	Date: _____
-------------	--------------	--------------	-------------

Track Conditions	<input type="checkbox"/> Indoor	<input type="checkbox"/> Tight	<input type="checkbox"/> Smooth	<input type="checkbox"/> Hard Packed	<input type="checkbox"/> Wet	<input type="checkbox"/> Grass	<input type="checkbox"/> Low Bite	<input type="checkbox"/> High Bite
	<input type="checkbox"/> Outdoor	<input type="checkbox"/> Open	<input type="checkbox"/> Rough	<input type="checkbox"/> Loose/Loamy	<input type="checkbox"/> Dry	<input type="checkbox"/> Astro Turf	<input type="checkbox"/> Med Bite	<input type="checkbox"/> Other _____

Front Suspension	
Shock 2/4: _____	Piston Holes: _____
Toe-in: _____	Spring: _____
Toe-out: _____	Pre Load: _____
Ride Height: _____	Shock Location: _____
Caster: _____	Piston/Oil: _____
Droop Max: _____	Bump Steer: _____
Anti Roll Bar: _____	Camber Link: _____

Differentials		
Diff Fluid: _____	Gear: _____	
Front _____	_____	
Center _____	_____	
Rear _____	_____	

Rear Suspension	
Shock 2/4: _____	Piston Holes: _____
Toe-in: _____	Spring: _____
Toe-out: _____	Pre Load: _____
Ride Height: _____	Shock Location: _____
Caster: _____	Piston/Oil: _____
Droop Max: _____	Bump Steer: _____
Anti Roll Bar: _____	Camber Link: _____

Engine	
Engine temperature: _____	Engine: _____
Airbox: _____	Spark Plug: _____
High Needle: _____	Muffler/Pipe: _____
Low Needle: _____	Fuel Mixture: _____
Gearing: _____	

Clutch	
Clutch Shoes and Springs Info	
_____	

Notes: _____

BUMP STEER



UP DOWN

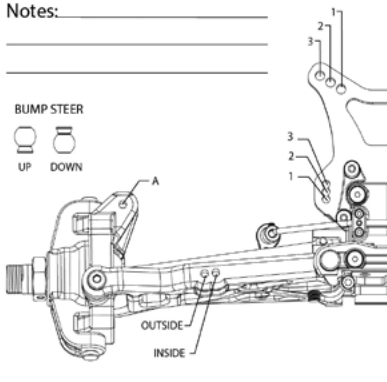

Notes: _____

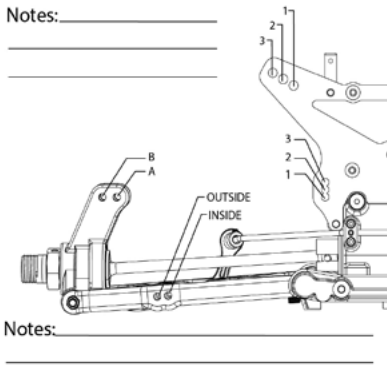

Notes: _____

Tires			
	Type	Compound	Insert
Front:	_____	_____	_____
Rear:	_____	_____	_____
Notes:	_____		

Notes: _____

EBBERSTON RC TRACK

Address

Ebberston RC Track, Partings Farm, Ebberston, Yorkshire, YO13 9PA

Track

Astroturf

Size

300m in length

Markers

Piping and Rope

Rostrum

Elevated position for 12 drivers

Pits

Grass, no onsite power trackside

Toilets

Ladies, Gents Porta Loos

Access

Disabled access to track and pits

Catering

Catering van onsite plus Supermarkets in Pickering and Scarborough



Setup Sheet

Name: _____	Event: _____	Track: _____	Date: _____
-------------	--------------	--------------	-------------

Track Conditions	<input type="checkbox"/> Indoor	<input type="checkbox"/> Tight	<input type="checkbox"/> Smooth	<input type="checkbox"/> Hard Packed	<input type="checkbox"/> Wet	<input type="checkbox"/> Grass	<input type="checkbox"/> Low Bite	<input type="checkbox"/> High Bite
	<input type="checkbox"/> Outdoor	<input type="checkbox"/> Open	<input type="checkbox"/> Rough	<input type="checkbox"/> Loose/Loamy	<input type="checkbox"/> Dry	<input type="checkbox"/> Astro Turf	<input type="checkbox"/> Med Bite	<input type="checkbox"/> Other _____

Front Suspension	
Shock 2/4: _____	Piston Holes: _____
Toe-in: _____	Spring: _____
Toe-out: _____	Pre Load: _____
Ride Height: _____	Shock Location: _____
Caster: _____	Piston/Oil: _____
Droop Max: _____	Bump Steer: _____
Anti Roll Bar: _____	Camber Link: _____

Differentials		
	Diff Fluid: _____	Gear: _____
Front	_____	_____
Center	_____	_____
Rear	_____	_____

Rear Suspension	
Shock 2/4: _____	Piston Holes: _____
Toe-in: _____	Spring: _____
Toe-out: _____	Pre Load: _____
Ride Height: _____	Shock Location: _____
Caster: _____	Piston/Oil: _____
Droop Max: _____	Camber Link: _____
Anti Roll Bar: _____	

Engine	
Engine temperature: _____	Engine: _____
Airbox: _____	Spark Plug: _____
High Needle: _____	Muffler/Pipe: _____
Low Needle: _____	Fuel Mixture: _____
Gearing: _____	

Clutch	
Clutch Shoes and Springs Info	
_____	

Notes: _____

BUMP STEER

 UP DOWN

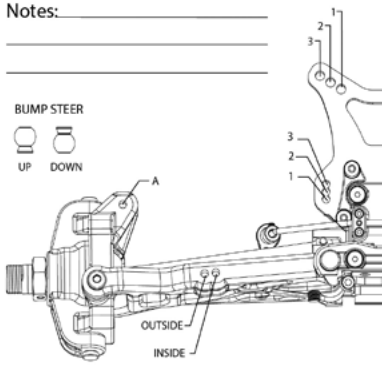

Diagram showing front suspension components with callouts 1, 2, 3 and A, B, C. Labels include OUTSIDE and INSIDE.

Notes: _____

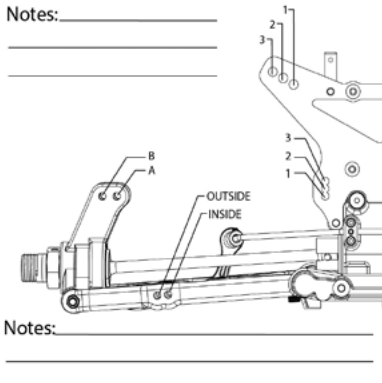

Diagram showing rear suspension components with callouts 1, 2, 3 and A, B, C. Labels include OUTSIDE and INSIDE.

Tires			
	Type	Compound	Insert
Front:	_____	_____	_____
Rear:	_____	_____	_____
Notes:	_____		

Notes: _____

LINCOLNSHIRE RADIO CCC

Address

Lincolnshire Radio CCC, Fen Road, Dorrington, Lincolnshire, LN4 3QB

Track

Astroturf

Size

400m in length

Markers

Hose, Tyres

Rostrum

Covered, elevated position for 10 drivers

Pits

Grass. No mains power available

Toilets

Ladies and gents

Access

Disabled access to track and pits

Catering

Catering van or Supermarkets in Sleaford and Ruskington

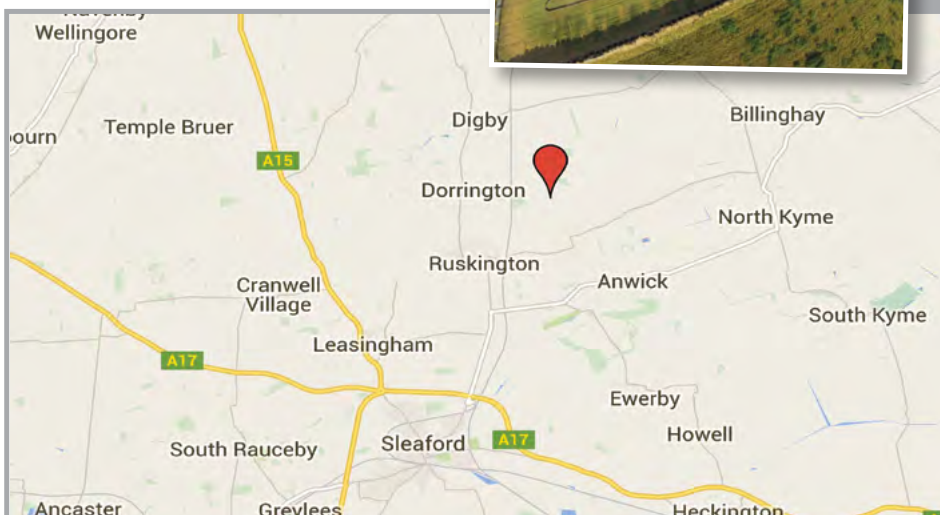

Setup Sheet

Name: _____	Event: _____	Track: _____	Date: _____
-------------	--------------	--------------	-------------

Track Conditions	<input type="checkbox"/> Indoor	<input type="checkbox"/> Tight	<input type="checkbox"/> Smooth	<input type="checkbox"/> Hard Packed	<input type="checkbox"/> Wet	<input type="checkbox"/> Grass	<input type="checkbox"/> Low Bite	<input type="checkbox"/> High Bite
	<input type="checkbox"/> Outdoor	<input type="checkbox"/> Open	<input type="checkbox"/> Rough	<input type="checkbox"/> Loose/Loamy	<input type="checkbox"/> Dry	<input type="checkbox"/> Astro Turf	<input type="checkbox"/> Med Bite	<input type="checkbox"/> Other _____

Front Suspension	
Shock 2/4: _____	Piston Holes: _____
Toe-in: _____	Spring: _____
Toe-out: _____	Pre Load: _____
Ride Height: _____	Shock Location: _____
Caster: _____	Piston/Oil: _____
Droop Max: _____	Bump Steer: _____
Anti Roll Bar: _____	Camber Link: _____

Differentials		
	Diff Fluid: _____	Gear: _____
Front	_____	_____
Center	_____	_____
Rear	_____	_____



Rear Suspension	
Shock 2/4: _____	Piston Holes: _____
Toe-in: _____	Spring: _____
Toe-out: _____	Pre Load: _____
Ride Height: _____	Shock Location: _____
Caster: _____	Piston/Oil: _____
Droop Max: _____	Camber Link: _____
Anti Roll Bar: _____	

Engine	
Engine temperature: _____	Engine: _____
Airbox: _____	Spark Plug: _____
High Needle: _____	Muffler/Pipe: _____
Low Needle: _____	Fuel Mixture: _____
Gearing: _____	

Clutch	
Clutch Shoes and Springs Info	
_____	

Notes: _____

BUMP STEER

 UP  DOWN

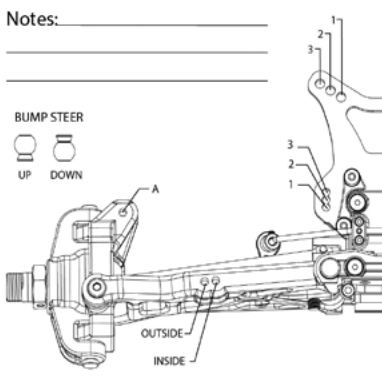

Notes: _____

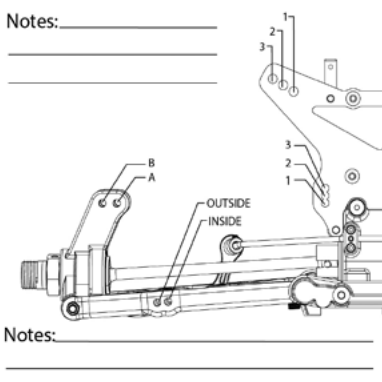

Notes: _____

Tires			
	Type	Compound	Insert
Front:	_____	_____	_____
Rear:	_____	_____	_____
Notes:	_____		

Notes: _____

PICKERING RACEWAY

Address

Pickering RC, Riseborough, Pickering, Yorkshire, YO18 8LU

Track

Grass and Astroturf

Size

400m in length

Markers

Piping, Tyres

Rostrum

Covered, elevated position for 10 drivers

Pits

Grass, no onsite power trackside

Toilets

Portaloos Ladies and Gents

Access

Disabled access to track and pits

Catering

Try's to provide catering van. Supermarkets and takeaways in Pickering

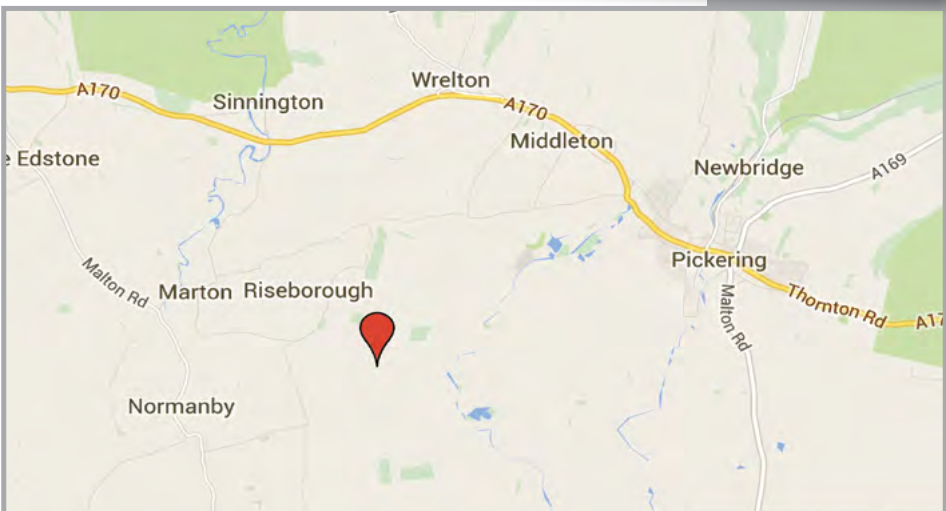

Setup Sheet

Name: _____	Event: _____	Track: _____	Date: _____
-------------	--------------	--------------	-------------

Track Conditions	<input type="checkbox"/> Indoor	<input type="checkbox"/> Tight	<input type="checkbox"/> Smooth	<input type="checkbox"/> Hard Packed	<input type="checkbox"/> Wet	<input type="checkbox"/> Grass	<input type="checkbox"/> Low Bite	<input type="checkbox"/> High Bite
	<input type="checkbox"/> Outdoor	<input type="checkbox"/> Open	<input type="checkbox"/> Rough	<input type="checkbox"/> Loose/Loamy	<input type="checkbox"/> Dry	<input type="checkbox"/> Astro Turf	<input type="checkbox"/> Med Bite	<input type="checkbox"/> Other _____

Front Suspension	
Shock 2/4: _____	Piston Holes: _____
Toe-in: _____	Spring: _____
Toe-out: _____	Pre Load: _____
Ride Height: _____	Shock Location: _____
Caster: _____	Piston/Oil: _____
Droop Max: _____	Bump Steer: _____
Anti Roll Bar: _____	Camber Link: _____

Differentials		
	Diff Fluid: _____	Gear: _____
Front	_____	_____
Center	_____	_____
Rear	_____	_____



Rear Suspension	
Shock 2/4: _____	Piston Holes: _____
Toe-in: _____	Spring: _____
Toe-out: _____	Pre Load: _____
Ride Height: _____	Shock Location: _____
Caster: _____	Piston/Oil: _____
Droop Max: _____	Bump Steer: _____
Anti Roll Bar: _____	Camber Link: _____

Engine	
Engine temperature: _____	Engine: _____
Airbox: _____	Spark Plug: _____
High Needle: _____	Muffler/Pipe: _____
Low Needle: _____	Fuel Mixture: _____
Gearing: _____	

Clutch	
Clutch Shoes and Springs Info	
_____	

Notes: _____

BUMP STEER

UP DOWN

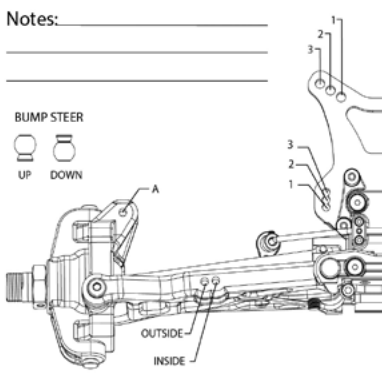

Notes: _____

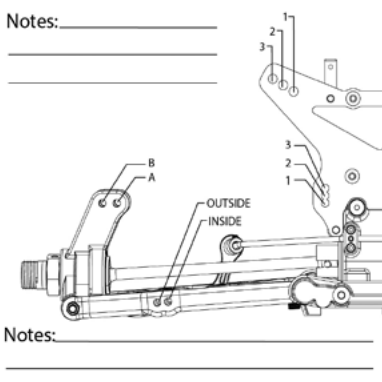

Notes: _____

Tires			
	Type	Compound	Insert
Front:	_____	_____	_____
Rear:	_____	_____	_____
Notes:	_____		

Notes: _____





MMR RACEWAY



Address

MMR Raceway, Hanger 88, Hullavington Airfield, Hullavington, Chippenham, SN14 6GU

Track

Astroturf

Size

300m in length

Markers

Twin Wall Piping, Tyres and Road Safety Barriers

Rostrum

Elevated position for 12 drivers

Pits

Grass and Astroturf areas, no onsite power trackside

Toilets

Ladies, Gents

Access

Disabled access to track and pits

Catering

Onsite catering @ M4 Karting. Supermarkets in Chippenham

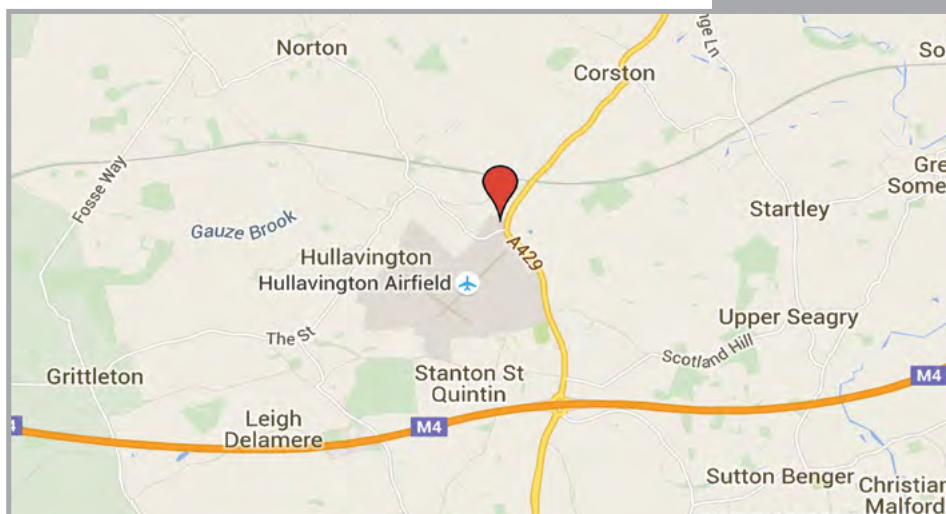

Setup Sheet

Name: _____	Event: _____	Track: _____	Date: _____
-------------	--------------	--------------	-------------

Track Conditions	<input type="checkbox"/> Indoor	<input type="checkbox"/> Tight	<input type="checkbox"/> Smooth	<input type="checkbox"/> Hard Packed	<input type="checkbox"/> Wet	<input type="checkbox"/> Grass	<input type="checkbox"/> Low Bite	<input type="checkbox"/> High Bite
	<input type="checkbox"/> Outdoor	<input type="checkbox"/> Open	<input type="checkbox"/> Rough	<input type="checkbox"/> Loose/Loamy	<input type="checkbox"/> Dry	<input type="checkbox"/> Astro Turf	<input type="checkbox"/> Med Bite	<input type="checkbox"/> Other _____

Front Suspension	
Shock 2/4: _____	Piston Holes: _____
Toe-in: _____	Spring: _____
Toe-out: _____	Pre Load: _____
Ride Height: _____	Shock Location: _____
Caster: _____	Piston/Oil: _____
Droop Max: _____	Bump Steer: _____
Anti Roll Bar: _____	Camber Link: _____

Differentials		
	Diff Fluid: _____	Gear: _____
Front	_____	_____
Center	_____	_____
Rear	_____	_____



Rear Suspension	
Shock 2/4: _____	Piston Holes: _____
Toe-in: _____	Spring: _____
Toe-out: _____	Pre Load: _____
Ride Height: _____	Shock Location: _____
Caster: _____	Piston/Oil: _____
Droop Max: _____	Bump Steer: _____
Anti Roll Bar: _____	Camber Link: _____

Engine	
Engine temperature: _____	Engine: _____
Airbox: _____	Spark Plug: _____
High Needle: _____	Muffler/Pipe: _____
Low Needle: _____	Fuel Mixture: _____
Gearing: _____	

Clutch	
Clutch Shoes and Springs Info	
_____	

Notes: _____

BUMP STEER

 UP  DOWN

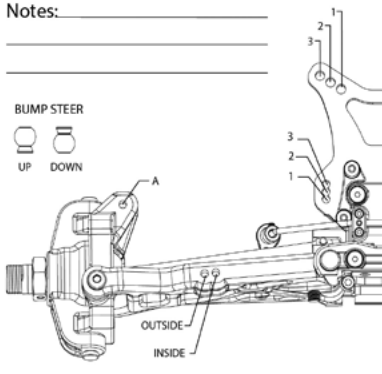

Notes: _____

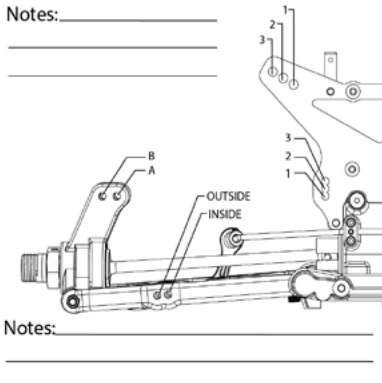

Notes: _____

Tires			
	Type	Compound	Insert
Front:	_____	_____	_____
Rear:	_____	_____	_____
Notes:	_____		

Notes: _____

PICKERING RACEWAY

Address

Pickering RC, Riseborough, Pickering, Yorkshire, YO18 8LU

Track

Grass and Astroturf

Size

400m in length

Markers

Piping, Tyres

Rostrum

Covered, elevated position for 10 drivers

Pits

Grass, no onsite power trackside

Toilets

Portaloos Ladies and Gents

Access

Disabled access to track and pits

Catering

Try's to provide catering van. Supermarkets and takeaways in Pickering

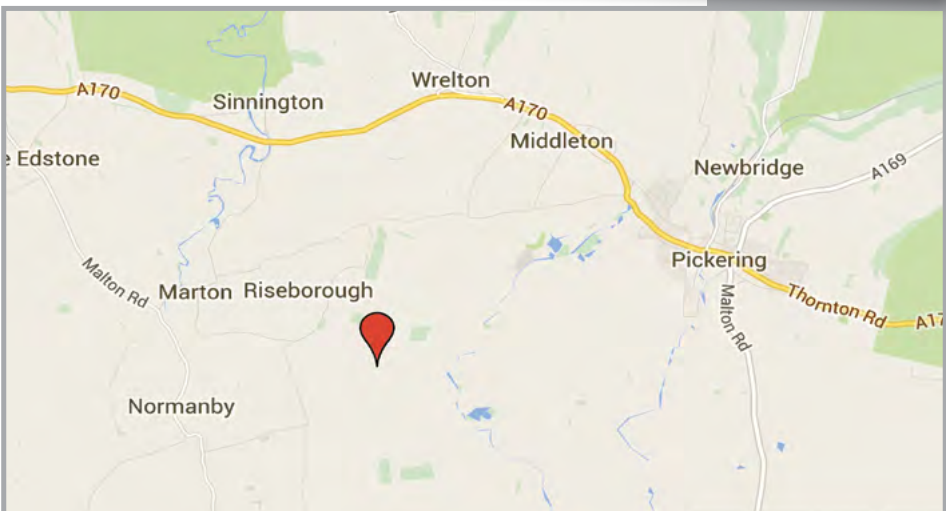

Setup Sheet

Name: _____	Event: _____	Track: _____	Date: _____
-------------	--------------	--------------	-------------

Track Conditions	<input type="checkbox"/> Indoor	<input type="checkbox"/> Tight	<input type="checkbox"/> Smooth	<input type="checkbox"/> Hard Packed	<input type="checkbox"/> Wet	<input type="checkbox"/> Grass	<input type="checkbox"/> Low Bite	<input type="checkbox"/> High Bite
	<input type="checkbox"/> Outdoor	<input type="checkbox"/> Open	<input type="checkbox"/> Rough	<input type="checkbox"/> Loose/Loamy	<input type="checkbox"/> Dry	<input type="checkbox"/> Astro Turf	<input type="checkbox"/> Med Bite	<input type="checkbox"/> Other _____

Front Suspension	
Shock 2/4: _____	Piston Holes: _____
Toe-in: _____	Spring: _____
Toe-out: _____	Pre Load: _____
Ride Height: _____	Shock Location: _____
Caster: _____	Piston/Oil: _____
Droop Max: _____	Bump Steer: _____
Anti Roll Bar: _____	Camber Link: _____

Differentials		
	Diff Fluid: _____	Gear: _____
Front	_____	_____
Center	_____	_____
Rear	_____	_____



Rear Suspension	
Shock 2/4: _____	Piston Holes: _____
Toe-in: _____	Spring: _____
Toe-out: _____	Pre Load: _____
Ride Height: _____	Shock Location: _____
Caster: _____	Piston/Oil: _____
Droop Max: _____	Bump Steer: _____
Anti Roll Bar: _____	Camber Link: _____

Engine	
Engine temperature: _____	Engine: _____
Airbox: _____	Spark Plug: _____
High Needle: _____	Muffler/Pipe: _____
Low Needle: _____	Fuel Mixture: _____
Gearing: _____	

Clutch	
Clutch Shoes and Springs Info	
_____	

Notes: _____

BUMP STEER

UP DOWN

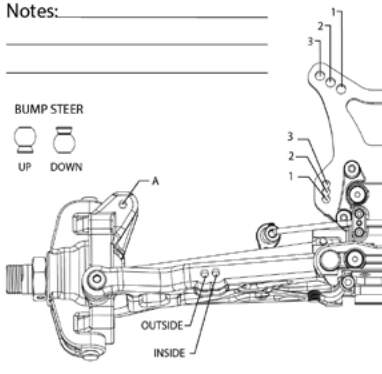

Notes: _____

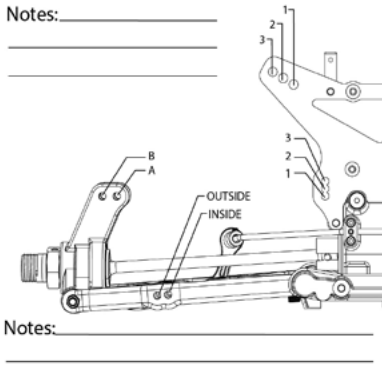

Notes: _____

Tires			
	Type	Compound	Insert
Front:	_____	_____	_____
Rear:	_____	_____	_____
Notes:	_____		

Notes: _____

LINCOLNSHIRE RADIO CCC

Address

Lincolnshire Radio CCC, Fen Road, Dorrington, Lincolnshire, LN4 3QB

Track

Astroturf

Size

400m in length

Markers

Hose, Tyres

Rostrum

Covered, elevated position for 10 drivers

Pits

Grass. No mains power available

Toilets

Portaloos Ladies and Gents

Access

Disabled access to track and pits

Catering

Catering van or Supermarkets in Sleaford and Ruskington

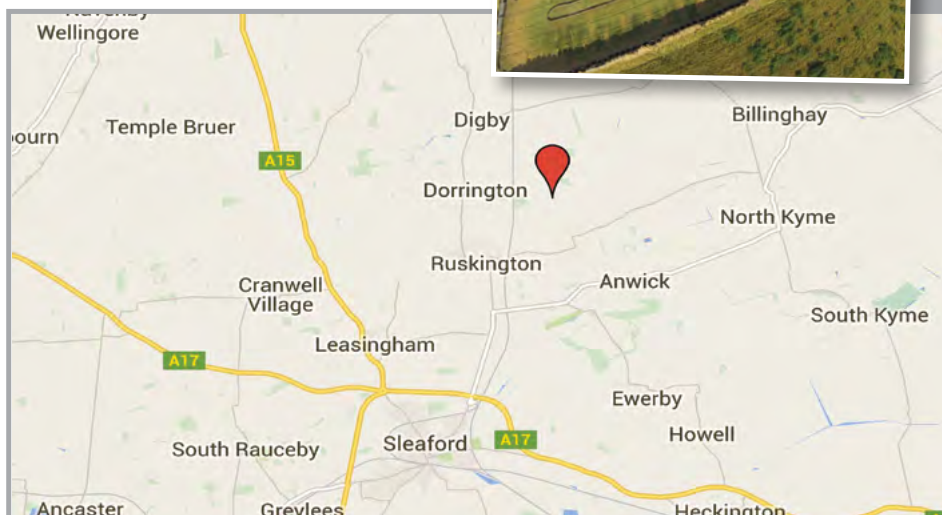

Setup Sheet

Name: _____	Event: _____	Track: _____	Date: _____
-------------	--------------	--------------	-------------

Track Conditions	<input type="checkbox"/> Indoor	<input type="checkbox"/> Tight	<input type="checkbox"/> Smooth	<input type="checkbox"/> Hard Packed	<input type="checkbox"/> Wet	<input type="checkbox"/> Grass	<input type="checkbox"/> Low Bite	<input type="checkbox"/> High Bite
	<input type="checkbox"/> Outdoor	<input type="checkbox"/> Open	<input type="checkbox"/> Rough	<input type="checkbox"/> Loose/Loamy	<input type="checkbox"/> Dry	<input type="checkbox"/> Astro Turf	<input type="checkbox"/> Med Bite	<input type="checkbox"/> Other _____

Front Suspension	
Shock 2/4: _____	Piston Holes: _____
Toe-in: _____	Spring: _____
Toe-out: _____	Pre Load: _____
Ride Height: _____	Shock Location: _____
Caster: _____	Piston/Oil: _____
Droop Max: _____	Bump Steer: _____
Anti Roll Bar: _____	Camber Link: _____

Differentials		
	Diff Fluid: _____	Gear: _____
Front	_____	_____
Center	_____	_____
Rear	_____	_____



Rear Suspension	
Shock 2/4: _____	Piston Holes: _____
Toe-in: _____	Spring: _____
Toe-out: _____	Pre Load: _____
Ride Height: _____	Shock Location: _____
Caster: _____	Piston/Oil: _____
Droop Max: _____	Bump Steer: _____
Anti Roll Bar: _____	Camber Link: _____

Engine	
Engine temperature: _____	Engine: _____
Airbox: _____	Spark Plug: _____
High Needle: _____	Muffler/Pipe: _____
Low Needle: _____	Fuel Mixture: _____
Gearing: _____	

Clutch	
Clutch Shoes and Springs Info	
_____	

Notes: _____

BUMP STEER

UP DOWN

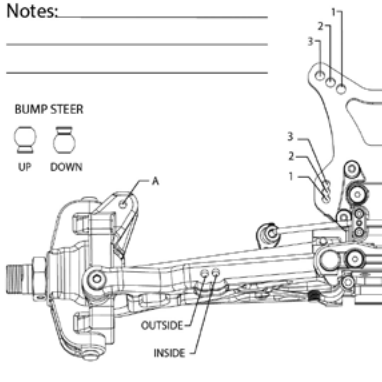

Notes: _____

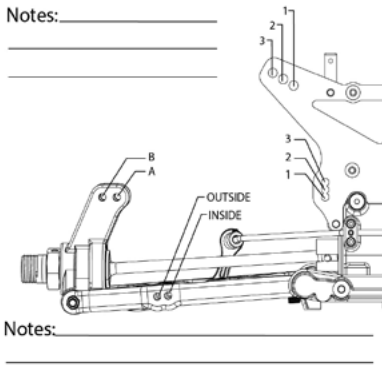

Notes: _____

Tires			
	Type	Compound	Insert
Front:	_____	_____	_____
Rear:	_____	_____	_____
Notes:	_____		

Notes: _____

NENE VALLEY RACEWAY

Address

Nene Valley Raceway, Airfield Road, Podington,
Wellingborough, Northamptonshire, NN29 7XA

Track

Astroturf

Size

70m x 40m,
400m in length

Markers

Black marine rope, rubber
corner boards

Rostrum

40ft covered rostrum with
single stair access

Pits

Astroturf area with 240V
power at a nominal
meeting fee

Toilets

Ladies, Gents

Access

Disabled access to track
and pits

Catering

Onsite catering.
Supermarkets, hotels and
takeaways local



Setup Sheet

Name: _____	Event: _____	Track: _____	Date: _____
-------------	--------------	--------------	-------------

Track Conditions	<input type="checkbox"/> Indoor	<input type="checkbox"/> Tight	<input type="checkbox"/> Smooth	<input type="checkbox"/> Hard Packed	<input type="checkbox"/> Wet	<input type="checkbox"/> Grass	<input type="checkbox"/> Low Bite	<input type="checkbox"/> High Bite
	<input type="checkbox"/> Outdoor	<input type="checkbox"/> Open	<input type="checkbox"/> Rough	<input type="checkbox"/> Loose/Loamy	<input type="checkbox"/> Dry	<input type="checkbox"/> Astro Turf	<input type="checkbox"/> Med Bite	<input type="checkbox"/> Other _____

Front Suspension	
Shock 2/4: _____	Piston Holes: _____
Toe-in: _____	Spring: _____
Toe-out: _____	Pre Load: _____
Ride Height: _____	Shock Location: _____
Caster: _____	Piston/Oil: _____
Droop Max: _____	Bump Steer: _____
Anti Roll Bar: _____	Camber Link: _____

Differentials		
	Diff Fluid: _____	Gear: _____
Front	_____	_____
Center	_____	_____
Rear	_____	_____



Rear Suspension	
Shock 2/4: _____	Piston Holes: _____
Toe-in: _____	Spring: _____
Toe-out: _____	Pre Load: _____
Ride Height: _____	Shock Location: _____
Caster: _____	Piston/Oil: _____
Droop Max: _____	Bump Steer: _____
Anti Roll Bar: _____	Camber Link: _____

Engine	
Engine temperature: _____	Engine: _____
Airbox: _____	Spark Plug: _____
High Needle: _____	Muffler/Pipe: _____
Low Needle: _____	Fuel Mixture: _____
Gearing: _____	

Clutch	
Clutch Shoes and Springs Info	
_____	

Notes: _____

BUMP STEER

UP DOWN

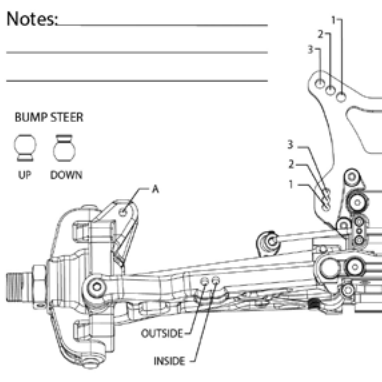

Notes: _____

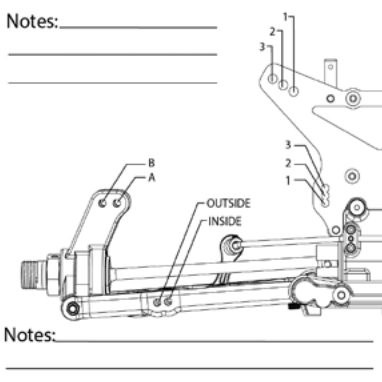

Notes: _____

Tires			
	Type	Compound	Insert
Front:	_____	_____	_____
Rear:	_____	_____	_____
Notes:	_____		

Notes: _____

WS MAX ULTIMATE



innovation

durability

power

precision

control

**EUROPEAN
CHAMPION**

**MCD
Racing**

TIRE OPTIONS

**MCD
Racing**

All MCD tires come with diverse compounds that work better under different circumstances.



	Xross-Max	Block-Stud	Micro-Stud V2	Dirt-Max	Astro-Max	Astro-Grip
Compounds:	BS & WS	BS	BS & BM	BS & BM	WM & WH	WS & WM

**MCD
Racing**

RadioLink

-power

ZENOAH®

Exclusively Distributed By:

www.kingcobra.co.uk
01706 250007 / sales@kingcobra.co.uk

Trade Inquiries Welcome

DISTRIBUTION
TEAM
KER



LARGE SCALE OFF-ROAD SECTION 2019 PROCEDURAL RULES



Table of contents

- | | | |
|---|------------------------------|--------------------------------|
| 1. Classes of Racing | 7. Referees | 14. Penalties |
| 2. Championship Period | 8. Racing Procedures | 15. International Teams |
| 3. General Standards for BRCA Sanctioned Meetings | 9. Marshalling | 16. Protests at a race meeting |
| 4. Track Specifications | 10. Track Side Repairs | 17. Post Meeting Protests |
| 5. Administration | 11. Parc fermé & Marshalling | 18. Section AGM |
| 6. Officers of the Meeting | 12. Curtailment Procedures | 19. AGM Proposals |
| | 13. Finals | 20. Section Refund Policy |

1. CLASSES OF RACING

1.1 BUGGY CLASS

1.1.1 This racing class welcomes 2 and 4 wheel drive buggies.

1.1.2 BRCA 2 Wheel Drive Buggy Championship will be for entrants in accordance with LSOR Construction Rule 1.7

1.1.3 BRCA 4 Wheel Drive Buggy Championship will be for entrants in accordance with LSOR Construction Rule 1.8

1.2 SHORT COURSE CLASS

1.2.1 This class is our newest class and is for the short course truck.

1.2.2 BRCA Short Course Championship is for entrants in accordance with LSOR Construction Rule 1.9

1.3 OPEN CLASS

1.3.1 This class is for any large scale vehicle which falls outside of 1.1 and 1.2 above but is within the BRCA generic rules for a radio control vehicle. Please see LSOR Construction Rule 1.10.

1.4 SCRUTINEERING

1.4.1 Scrutineering will be on a random basis, with a size box, being provided to allow drivers to check their vehicle dimensions. Any driver or marshal can ask for a particular car to be checked, if there are grounds for suspecting it's conformity to the rules.

1.5 TRANSPONDERS

1.5.1 All National events are timed using a MYLAPS RC4 decoder and as such all drivers are to ensure their personal transponder works with the timing device. The Race Director is not responsible for any missed laps during the meeting. They will inform any driver of any transponder issues at the earliest opportunity during the meeting. From 2016 the section will no longer have available handout transponders, any new racer will be offered the loan, if available, of a Harry transponder for their first meeting.

2. CHAMPIONSHIP PERIOD

2.1 The BRCA LSOR National championship is an 8-round championship which runs from spring each year until just before the BRCA AGM in October.

2.2 Within each classed race there will be three titles available, depending on numbers, a National champion, Clubman champion and also a Junior champion for the season.

2.3 Each championship is awarded on points from the best 5 rounds of the season, if there is a tie then the sections Non-scoring countback rules apply which means the points from the 6th meeting are used to see who finished the highest, if this is a tie then the 7th meeting results are then used.

2.4 The clubman championship excludes those drivers who have regularly achieve an A final from the 2011 to 2018 race seasons and achieved a nominal score per round set by the LSOR committee annually. Drivers may be promoted and demoted between the championships by the LSOR committee but normally once a Clubman driver is classified as a National driver they will always be classed as a National driver no matter what results they achieve in the series unless a gap of 3 years is present from their last meeting.

2.5 The junior championship is open to anyone under the age of 16 at the first round of the season.

3. GENERAL STANDARDS FOR BRCA SANCTIONED MEETINGS

3.1 Sanctions are only granted, on application, by the BRCA LSOR Committee. All submissions must be received for consideration ahead of the Section AGM; the calendar will be published before the start of the next season. Dates are subject to 'force majeure'

3.2 Nationals must be arranged by a club organisation unless 'force majeure' dictates otherwise.

3.3 It is the national venues responsibility to arrange the collection and return of any equipment which traditionally the race director has transported to their round(s), The race director/time keeper will transport to each national: - Sections laptops, router, printer, twin mic system, and timing decoder

3.4 Clubs are reminded that the ideal track specification is a minimal 4m width with an ideal gap of 1m between the safety fence and outer track edge where possible.

3.5 Vulnerable marshal points are to have 3-sided protection (infield positions) for added safety.

3.6 Due to the inclement weather host venues for a national event must have, or provision for a roof on their rostrum to protect all competitors/officials from the elements.

- 3.7 The section also recommends that during the clubs open practice session that drivers on the rostrum are limited to no more than the venues marshal points.
 - 3.8 Clubs need to provide toilets, a wired PA speaker system (the section will bring its own amp and mic) which is available to all drivers on and off the rostrum.
 - 3.9 If possible, provision for a waterproof Parc fermé and scrutining area along with a suitable monitor and cable set up to display the race results and our noise system display outside of race control once connected to the VGA\HDMI output on the Race Directors PC's.
 - 3.10 To help with the drivers experience of attending a national venue it is recommend that the host club provides a track map which can be used to identify the marshal points in use and their number.
 - 3.11 To help keep the venue tidy and ease of post event tidying up it is recommended that the venue makes use of hiring a skip for the duration of the meeting.
 - 3.12 Where evening entertainment has been provided for the driver's enjoyment it is anticipated that by midnight it will have died out and any generators will also be turned off as well.
 - 3.13 The section wishes to remind all host clubs that it recommends opening your venue from Saturday, opening before is at the clubs own discretion.
 - 3.14 LSOR host clubs must not hold club days on National race dates or the AGM date.
 - 3.15 Health & Safety. BRCA General Rules - see BRCA Handbook. The main straight and any associated sweeping corners must be fenced or located so that the general public are protected from any potential hazard.
- ## 4. TRACK SPECIFICATIONS
- 4.1 The track should be positioned to minimise any unfenced (over and above the track edging) track edges accessible to the public or racers. Spectators and marshals are to be protected from the risk of being hit by cars. A suitable safety fence is to be constructed to protect marshals in dangerous areas such as the end of the straight, or points where traffic on another part of the track is travelling towards the marshal from behind.
 - 4.2 The width of track is to be measured between the track markings with the track ideally being a minimum width of 4m. There may be a single point of the track layout where the width may be reduced by 1m [i.e. to 3m] for a maximum length of up to 10m.
 - 4.3 Corner cutting must be discouraged by the placing of adequate corner markings and barriers.
 - 4.4 Track marking equipment must be such a shape and size to prevent the entrapment of a car or the driver's view becoming obscured. All track markings are to be as flexible as possible and of material to cause minimal damage to a competitors vehicle and minimise the risks of the cars becoming airborne.
 - 4.5 The loop, 1m penalty box (if provided), start and finish lines shall be clearly marked on the track. The start line must be placed so that race officials have a clear view to identify any jump starts.
 - 4.6 Drivers must have a clear view of the full track from any position on the rostrum. The rostrum must be positioned to minimise the risk of people obstructing the driver's view. The rostrum ideally must be a minimum of 40' in length, 8' high and be able to accommodate 15 persons safely (i.e. with good margin). The front must have a safety rail and kickboard and the floor should be constructed of solid material and be all at one level. All steel rostrums must be fully earthed in at least two places. The rostrum must be secured safely to the ground with no risk of movement during the event.
 - 4.7 The rostrum may be marked into a minimum of 15 equal sections, enabling 14 drivers to see which space is available, as well as room for an official.
 - 4.8 For finals the drivers will take their positions in qualifying order to allow them their preferred position.
 - 4.9 The main straight where feasible to be on the opposite side of the track to the rostrum.
 - 4.10 No competitor should be pitting in the area designated as race control.
 - 4.11 Any person inside the safety fencing must be directly involved with the racing, i.e. marshals and mechanics. At the start of a heat or final, mechanics, on the release of the cars, must return to the pits as soon as possible, with marshals standing at their designated positions.

- 4.12 Track features will be 'vetted' before the commencement of a meeting and, with the agreement of the majority of Committee Members present, removed if deemed necessary. Over the weekend and no later than the start of the round on Sunday the sections safety officer, or nominee, and a representative of the club will review the associations risk assessment and note any exceptions and mitigation actions taken to ensure a safe meeting is run. The signed form shall be retained and a copy emailed to the association@riskassessment@brca.org within 3 days of the race meeting.
- 4.13 No car shall be used outside of the track vicinity at any time of a race week-end (including periods when the race event is not taking place). A small controlled area can be set up for use, to be completely fenced in by double fencing, at the Race Organiser's discretion. This is not compulsory on the Race Organiser.
- 4.14 No motorised bike/bicycle/scooter is allowed to be used within or outside of the track vicinity at any time of a race week-end (including periods when the race event is not taking place). This does not include motorised vehicles required for disabled members of the public.

5. ADMINISTRATION

- 5.1 Details of entry must be made available at least 28 days before the closing date of the event. Entries will be limited to nine heats each weekend. Entries and subsequent heat allocations by class must be dealt with on a first come, first served basis.
- 5.2 Entries for a meeting will only be accepted from current BRCA members and must be accompanied by their BRCA membership number. The entry fee will be set annually at the section AGM.
- 5.3 Race fees for the 2019 season are £20.00 per Adult entry, £5 per Junior entry for the first vehicle entered and for those wishing to enter a second vehicle then its £10.00 for adults and £2.50 for juniors.
- 5.4 Prior to the meetings drivers are to pre-register via the sections on-line booking system through the LSOR section area on the BRCA main website at www.brca.org or as indicated on our Facebook page.
- 5.5 For those without computer access then please pre-register by texting the sections

Race Director. All pre-registrations are to be done by 5pm the Wednesday preceding the meeting. On the day registration will be allowed but entry cannot be guaranteed and will incur a fee of £10 to the advertised race fee in 5.3.

- 5.6 Due to the popularity of our championship series we now run a round of qualification on Saturday afternoon. Booking in confirmation and payment therefore commences mid morning with ALL entries confirmed ahead of the drivers briefing. Any driver doing just the Sunday should pre-book online and make there payment to guarantee there place at the meeting.
- 5.7 Anyone attending a national meeting MUST wear hi-viz jackets when they are within the track area (within the fenced off area), on the rostrum, and includes collecting and placing your car in the pit lane. Any mechanics or anybody marshalling on a racers behalf will also need to be wearing a hi-viz top. The section no longer provides Hi-Viz tops and any driver who turns up without their hi-viz will be excluded from the meeting.
- 5.8 Anyone attending LSOR events wishing to fly any kind of aircraft must be a member of the BMFA, hold the required flying licence and is prohibited at all times the track is open and a meeting is underway. Where venues allow and you are suitably qualified to fly you may do so away from the track, pitting and attendees camping area.
- 5.9 All racers are reminded that the section rents the host club and as such the general conduct of entrants must be in line with the BRCA handbook.
- 5.10 In line with the associations constitution if the committee feel a driver is under the influence on race day they will be asked to prove their legibility to race by undergoing a breath test of which a positive outcome will exclude them from the days racing and recommend that they do not drive straight home.

6. OFFICERS OF THE MEETING

- 6.1 A sanctioned event must have the following officials present:
- A. Race Director and Chief timekeeper, who will be present in race control throughout the timed heats and finals checking that the timing equipment is operational and that all races have been started and finished in accordance to the rules.

- B. Two of the three Scrutineers from page 6, who will ensure that all cars meet the class requirements of the section.
 - C. Safety Officer, who will ensure that the host venue is safe and populate the required risk assessment with a club representative.
 - D. A track repair and maintenance nominee from the host club, who will ensure that all necessary track repairs and general maintenance/facilities tasks are carried out in a timely and satisfactory manner.
- 6.2 The BRCA Steward has absolute authority at race meetings and for interpretations of the rules.
 - 6.3 When feasible a Referee for each Heat and Final allocated by the BRCA Steward - see 7.1
 - 6.4 Notwithstanding the regulations within this handbook, the committee reserves the right that, at a race meeting, should a situation arise, requiring a decision, which is not met by the existing rulebook, the committee members, present at the meeting, shall be able to make a decision or interpret on existing rules to make a decision and that such decision shall stand.

7. REFEREES

- 7.1 Where practical a provision shall be made for a Referee in all heats and finals. This will usually be the sections own referee as listed on page 6 or a racer/racers nominated by the committee; these racer(s) will referee instead of marshalling. Failure to referee will bring the same penalty as failure to marshal.
- 7.2 The nominated racer(s) in rule 7.1 are to be announced at the driver's briefing.
- 7.3 The Referee should have an unobstructed view of the entire track, and preferably a view of the drivers on the rostrum.
- 7.4 The Referee may request drivers to allow a faster car to overtake, issue warnings to drivers, and issue penalties to drivers, refer to Rule 11 and Guidelines for Referees.
- 7.5 A microphone will be provided for the Referee, to allow clear communication to the driver's rostrum.

8. RACING PROCEDURES

- 8.1 Booking in will be open between 08:00-08:30 for those who can only make the Sunday. Saturday booking in will be between 11am and 2pm.

- 8.2 A driver's briefing (all racers and marshals to attend the briefing) will follow booking in, with racing commencing within 15 minutes of the drivers briefing with the sections aim of completing the last race around 6pm.
- 8.3 Where feasible open practice will be available for those who arrived on the Sunday ahead of the first heat of the day but this cannot be guaranteed.
- 8.4 The drivers briefing will include:
 - 1. Welcome and introduce the Race Officials by name.
 - 2. Clearly explain format of the event, including
 - [a] Number of heats, rounds and qualification system for finals
 - [b] Interval between qualifying rounds and between finals
 - 3. Explain procedures for finding out their heat, race number and frequency.
 - 4. Point out
 - [a] Entry/exit points for the track vicinity (including pit lane and rostrum)
 - [b] Luminous yellow jackets to be worn by all in pit lane
 - [c] The location of the results board
 - [d] Location of safety equipment
 - [e] Toilets, refreshments, etc.
 - 5. Explain the start/finish procedure:
 - [a] Qualifying - rolling start procedure
 - [b] Explain heat finish signals
 - 6. Explain marshalling procedure:
 - [a] Marshal the heat following your own
 - [b] First heat is marshalled by drivers from the last heat
 - [c] Substitution of marshals only allowed with Race Director's approval
 - [d] Marshalling shall only be done by drivers over the age of 16.
 - [e] All Marshals and Drivers must wear hi-viz tabards
 - 7. Mention any specific requirements from the local host club.
 - 8. Announce start time for first practice race.
- 8.5 There will only be a 4-minute break between heats, so drivers will need to be in the start area, with transponders fitted before the previous heat finishes. When feasible a 15-minute class break will occur before

- each class final. Durations of heats and finals is dependent upon attendance levels with heats ideally being 8 to 10 minutes in duration, and finals being between 10 and 30 minutes.
- 8.6 The Race Director in consultation with the LSOR committee members present will have the final call on durations taking into consideration weather conditions, current and anticipated time of completion.
 - 8.7 Drivers must be seeded on handicap for qualifying based upon current championship position and previous performance.
 - 8.8 Drivers must marshal one Heat after their own race, unless they have been designated as Referees (see 7.1) or instructed otherwise by race control. All marshals must be BRCA members and have attended the driver's briefing (or at least been asked to) and have received Section marshal training. If a competitor is unable to marshal for any reason then they must provide a suitable substitute after seeking permission to do so from the meeting steward. Failure to marshal or provide a substitute in qualifying will result in the loss of that competitor's fastest qualifying time. Failure to marshal or provide a substitute during finals will result in disqualification from the event. If a driver takes too long to get to their marshal post during the heat change over then this will result in the loss of that competitor's fastest qualifying time.
 - 8.9 The Race Director or Referee are to make sure there are sufficient marshals and that they are suitably spread around the track
 - 8.10 Competitors may only drive during their race and then only from the rostrum.
 - 8.11 Competitors not in the race must not interfere with the progress of any driver within a race or in the pits. Where feasible, no driver is to leave the rostrum until the race is declared over or unless instructed to do so by the Race Director for vehicle recovery.
 - 8.12 A race may not start unless in the presence of the Race Director or deputy or the appointed Race Referee.
 - 8.13 Rolling starts will be employed for the heats.
 - 8.14 The repair time between each round of heats will be at the Race Director's discretion, taking into account such factors as heat numbers, time of year, numbers of drivers, etc.
 - 8.15 Staggered start positions will be employed for the finals, with a nominal 4 meter gap between cars.
 - 8.16 In all finals the cars are to be placed on the track before the timing loop so when called to the starting line all transponders can be checked for operation and where possible the Race Director will inform the drivers of any failure, this will not stop the formation of the grid and any vehicle whose PT does not work returns to the pit lane and starts safely from there rather than traveling back to the grid, thus leaving a place on the grid.
 - 8.17 Only the Race Director, deputy or the appointed Race Referee may call for a restart or abandon a race.
 - 8.18 Each car in the national series will be inspected to ensure that it meets the requirements of the section handbook.
 - 8.19 Qualifying results will be posted after every round. Final results will be posted at least 10 minutes before prize ceremony.
 - 8.20 The trophies or prizes will be awarded at the end of the meeting.
 - 8.21 The committee recommends the use of a referee to assist drivers in all heats and finals.
 - 8.22 During a race, no-one other than the Race Control officials can pass any information to a competitor; this does not include drivers requesting one another to allow overtaking - or passing on information to each other regarding cars that have stopped on the circuit.
 - 8.23 It is the driver's responsibility to ensure the correct transponder is securely attached to their car and working. If the equipment should fall off, the car will not be counted.
 - 8.24 No refuelling is permitted during qualification heats or finals including warm-up time. Anyone refuelling on the track will be disqualified. Drivers are advised to have a small dry powder fire extinguisher to hand in their pits.
 - 8.25 The scrutineer will check for excessive noise and appropriate action will be taken, during the execution of the national series the section will be utilising an automatic recording system to record the noise levels as each vehicle passes a dedicated point on the circuit.
 - 8.26 It must be understood by all drivers that any failure of the exhaust system whilst out on

the circuit will require the car being removed immediately from the circuit until the fault is repaired, any driver who does not pull over/off within 2 laps of being notified will be penalised accordingly by the loss of their fastest lap in qualification or 1 lap penalty in their final.

- 8.27 Delays will not be allowed for heats and minor finals. In unforeseen circumstances, A driver may call a 10 minute delay at the beginning of their final up to the point of the first car being called to the line. Only one delay per final is allowed to be called. The 10 minutes is the maximum time a driver may have to repair their vehicle, if they are not ready after the time delay then the final will be started without them and they are free to join from the pit lane once the race has commenced. If the vehicle is repaired within the delay period and the Race Director is made aware that the driver is ready then at his discretion he may call the cars to the grid rather than waiting the remaining time. During the delay all remaining drivers and cars shall stay within the track perimeter/rostrum area waiting for the restart. During the delay period no other cars may be worked on or leave the pit lane area otherwise they will also be penalised and start behind the delayed start vehicle at the rear of the grid. All the other cars will start in their correct positions with gaps left in the grid from the penalised car/s which will then start in 11th, 12th etc. in order of receiving penalties.

9. MARSHALLING

- 9.1 When possible, the Scrutineer will not carry out any marshalling duties.
- 9.2 No one under 16 years of age is allowed to marshal.
- 9.3 Marshals must wear high visibility reflective vests or jackets, these are to be worn not only when marshalling but also when you are on the rostrum driving.
- 9.4 Marshals to be advised to wear stout shoes or boots and wear heavy duty gloves, safety glasses, and their own high visibility reflective vest/jacket.
- 9.5 If a car's engine has stopped, the car must be taken off the track, the marshal is allowed 3 pulls in attempting to restart the engine and that is all. If the car does not start, he must return to marshalling immediately, no other fixes or repairs are allowed to be performed.

- 9.6 Whilst marshalling drivers are reminded that there should be no smoking, drinking, use of mobile phones or cameras trackside.
- 9.7 In the first instance the driver shall marshal the post associated with their race number unless instructed by the race director or referee.

10. TRACK SIDE REPAIRS

- 10.1 No vehicle should be worked on track side after the attempted three pulls trying to restart them. Electric starters are not permitted on the track, pits and pitting areas only.
- 10.2 If the vehicle does not restart, it is the driver's responsibility to recover their vehicle and in doing so they must not take their radio transmitter onto the track, it must be left within the Parc fermé/rostrum area whilst recovering their vehicle and brought back to the pit table for repair.
- 10.3 If your vehicle has been taken out of the track area for repair during your heat then it should be returned to your designated Parc fermé slot to ensure no unfair advantage is gained from additional pit time during your designated marshalling period.
- 10.4 Any vehicle returning to the track should do so from the pit lane and exiting such device in the track direction of the meeting. Any one not adhering to this rule will be penalised by the Race Director.

11. PARC FERMÉ & MARSHALLING

- 11.1 Upon finishing each heat, each driver is to place their vehicle in the dedicated Parc fermé vehicle slot (car 1 in slot 1... car 10 in slot 10) after the previous vehicle has left the slot.
- 11.2 If your vehicle has been taken out of the track area for repair during your heat then it should be returned to your designated Parc fermé slot to ensure no unfair advantage is gained from additional pit time whilst you are marshalling.
- 11.3 Upon placing the vehicle in the slot the driver or nominee should go out to Marshal straight away and marshal their respective heat (vehicle remains in Parc fermé even with a nominee marshalling).
- 11.4 Upon receiving notice from the Race Director that the heat is over the marshal should collect their vehicle from Parc fermé and leave the track area once they have been relieved of their marshalling duties by the next rounds marshal.

- 11.5 Any driver who does not adhere to this procedure will be penalised with the loss of their FTQ during the heat the BRCA LSOR Race Director will review the vehicles in the Parc fermé area.
- 11.6 After the running of the Semi B final if double sided finals are used the top five vehicles are to be placed in Parc fermé for the duration of the Semi A final (those taken to the pits for work prior to the end of the semi are to be returned to the Parc fermé area) to ensure all main finalists have the same amount of time to prepare for the main final. Any driver caught working on their car will incur a 30 second penalty in the main final.
- 11.7 A head of each class "A" final all vehicles (empty of fuel) and drivers should go to Scrutineering and at the race directors\ scrutineers discretion a BRCA official will confirm that the driver's vehicle conforms to the class fuel limit requirements. Even if your vehicle is not checked it is your responsibility to ensure your tank holds the class maximum and no more.
- 13.4 After the three rounds the driver with the lowest 2 round points position is first overall and those scoring more will be ranked on their points above the first place driver.
- 13.5 The driver's lowest total can come from any combination of 2 from the 3 rounds.
- 13.6 Staggered start positions will be employed for the finals.
- 13.7 The finals will be either double sided with 5 drivers from each semi qualifying or single sided bump up format at the Race Director's discretion, drivers will be notified of race format at the drivers briefing. If double sided semis are run then the main final will be graded as follows:-

Semi-Final Finishing Position	A-Final Position
Fastest 1 st Place	1 st Place
Fastest 2 nd Place	3 rd Place
Fastest 3 rd Place	5 th Place
Fastest 4 th Place	7 th Place
Fastest 5 th Place	9 th Place

12. CURTAILMENT PROCEDURES

- 12.1 In the event of a 'rain off' situation, there will be a driver's vote to decide on one of the following courses of action: Cancellation of the meeting, re-running of the meeting, cancel the meeting from the championship or to close the meeting and award the points as per the last end of round overall qualification positions.
- 12.2 If an heat or final suffers a technical issue within race control (computer, decoder drop outs etc) and as not completed 50% race distance (time) it will be rerun, either directly or delayed until the end of the round. If 50% as been completed then the results will stand as at the last passing of the working system.

13. FINALS

- 13.1 The final positions will be based upon the drivers' best two scores from the three qualification rounds and their relative round position and associated points.
- 13.2 Points scored per round are based upon the laps completed and time achieved.
- 13.3 For all rounds the fastest driver (most laps in the shortest time) will score zero points. The second fastest will score 2, third fastest 3 and thereafter a point more per position in the round table up to the maximum of the class numbers.

- 13.8 Points will be awarded as follows:- the winning\highest driver per championship will receive 100 points, second place 99, third 98 and so on. The section uses the non scoring rounds count back rule for tied positions within its championships.
- 13.9 Drivers failing to complete a lap in their final will be awarded last place in that final. If this applies to more than one driver then qualifying positions will be used to determine the order, i.e. the higher qualifier will be placed before the lower.

14. PENALTIES

- 14.1 Jump starts in a final will result in a ten second penalty or if the final is restarted then the car starts from the back of the grid.
- 14.2 Failure to marshal or provide a substitute in qualifying: loss of fastest qualifying time.
- 14.3 Failure to marshal or provide a substitute during finals: disqualification from the event. Failure to marshal competently: loss of previous time or final result.
- 14.4 **Corner cutting:** - if a competitor cuts a corner deliberately or as a result of an accident then they must wait for the referee to instruct them to continue, or wait for a period of time so no track

advantage is gained or wait for a marshal to return their car to the point at which it originally left the track. Failure to do so will result in a one lap penalty being applied at the end of the race.

- 14.5 Technical inspection: - failure to meet the technical and dimensional requirements of these rules results in loss of heat/final time.
- 14.6 The black flag will be shown only by Race Director, Referee or deputy. The car it applies to must stop and be removed from the track unless otherwise instructed. Any car that loses its body, becomes a safety hazard, is causing damage to the track, fixings and markings and/or driving incompatible with general safety will be black flagged.
- 14.7 Any car that is intentionally or continually running into other cars so as to slow their progress will be issued with a penalty and/or warning by the Referee, and if it continues will be black flagged.**
- 14.8 A car that is black flagged is disqualified from that race.
- 14.9 If a race is subsequently abandoned, a black flagged driver can only take part in the rerun at the Race Directors discretion.
- 14.10 Penalties for warnings given for driving infringements are :-
First Warning - No penalty
Second Warning - Stop & Go penalty
Three successive warnings and/or penalties lead to disqualification from the meeting.
- 14.11 There will be a ten minute protest period between the end of qualifying and the start of the finals.
- 14.12 Failure to line up properly or stay stationary on the grid will incur a 10 second penalty. Drivers with this penalty must not complete the lap but must drive into the pit lane (or designated area) and wait for the allotted time until released by an official. If a driver puts in an extra lap after being called to the line he/she will be made to start from the back of the grid.
- 14.13 Excessive use of bad language on the rostrum or in race control will incur a warning. If this warning is not heeded a one lap penalty will be awarded.
- 14.14 Driving or otherwise behaving in a manner likely to cause injury to other drivers or spectators may result in disqualification from meeting.

- 14.15 If a driver is being lapped he/she must not intentionally block the overtaking car, neither must the overtaking driver use heavy tactics to enable him/her to pass the slower driver.
- 14.16 Drivers missing parts of the track out during the warm-up in order to spread themselves out for a good qualifying run and infringe any other vehicle circulating normally will receive a 10 second penalty.
- 14.17 Vehicles will be checked for excessive noise and appropriate action will be taken. The maximum permitted sound level for all cars/classes is 81dB (+4db tolerance), measured at 1 metre above the track and no less than 10 metres from the car. Drivers are encouraged to fit airboxes to meet the noise limit, however air boxes are not mandatory for any car passing the noise test. Any driver not passing the sound meter at their racing pace to obtain a lower reading will incur the same penalty as a car failing the check. Cars failing the noise level after at least 10 valid readings will be penalised by either the loss of FTQ or a 1 lap penalty if in a final. Under exceptional circumstances common sense will be used.

15. INTERNATIONAL TEAMS

- 15.1 Where applicable team selection shall be based upon the season championship standing if the UKs allocation is limited and the number of drivers wishing to attend exceeds our allocation. Drivers must have competed in enough meetings to be eligible for the Championship. The LSOR committee may allocate up to 20% of the available places for EFRA/IFMAR events at their discretion to cater for reallocation.
- 15.2 Whilst the BRCA LSOR section welcomes drivers who wish to represent the section as part of an international team it should be noted that any driver who represents the section should be willing to attend all team meetings and undertake their marshaling duties during the event as rostered by the team manager/needs of the event. If team members decide not to attend these meetings, support the team or leave before they have completed all their marshaling duties then the section will not necessarily guarantee their place at a subsequent event when requested by the member.

16. PROTESTS AT A RACE MEETING

- 16.1 All protests must be made in writing to the Race Director, together with a £20.00

deposit. If the protest is upheld, this money will be reimbursed. The protest period of fifteen minutes shall commence when the results are published on the results board. Protests regarding the legality of cars must be made in writing, together with the fee, to the Race Director.

- 16.2 If any protest is made against a competitor, then that protest must be held in the full knowledge of that competitor. The accused competitor will be consulted and allowed to defend his actions before a decision is reached.

17. POST MEETING PROTESTS

- 17.1 All protests must be made in writing and received by the section chairman within 48 hours of the effected national sanctioned meeting, together with a £40.00 deposit. Within 30 calendar days of the effected national sanctioned meeting any protest will be investigated and closed out by the section committee. If the protest is upheld, this money will be reimbursed.
- 17.2 If any protest is made against a competitor, then that protest must be held in the full knowledge of that competitor. The accused competitor will be consulted and allowed to defend his actions before a decision is reached.

18. SECTION AGM

- 18.1 The sections AGM and trophy presentation will be notified on the BRCA's website with them being held at either the associations AGM or at another advertised time within the race season.

- 18.2 The section may call an EGM during the season if required to amend or improve the rules within this handbook.
- 18.3 Any AGM or EGM will be open to all BRCA members who have an interest in large scale off road matters and will be executed in accordance with the BRCA constitution and processes

19. AGM PROPOSALS

- 19.1 All AGM proposals (rule changes, committee member nominations and track submissions) are to be submitted to the Large Scale Off-Road section secretary at lsorsec@brca.org by the deadline issued by the section ahead of its AGM using the BRCA proposal form referenced within the sections call-in notice. All proposals will be processed and published online on the BRCA website.
- 19.2 Any proposals not received by the deadline can only be discussed at the AGM under "Any Other Business" and may then be subject to a time limit rule at the chairman's discretion.
- 19.3 At the AGM, no proposals can be accepted with the proviso that the person who proposed them is kept anonymous at the meeting.

20. SECTION REFUND POLICY

- 20.1 The section offers a full refund to any driver who pays their race entry ahead of the race meeting and is unable to participate on race day.





BRCA
BRITISH RADIO CAR ASSOCIATION

LARGE SCALE OFF-ROAD SECTION 2019 CONSTRUCTION RULES



1. CONSTRUCTION RULES

1.1 The essence of the sport of radio-controlled car racing is competition between models of racing automobiles. All cars must comply with dimensional requirements stated in these Rules.

1.2 There are to be no exposed carbon fibre body, wings, or any GRP (glass reinforced plastics) these materials may only be used under the bodyshell, or in the construction of shock towers or chassis.

1.3 Wings or bumpers must not be made from metal.

1.4 Bumpers are to be made from a flexible material and are optional at the rear but are mandatory to the front of your vehicle.

1.5 1.5 Bumpers must be designed to minimise injury that could result from being hit by a car, also to reduce the risk of damage to other cars

1.6 The front bumper shall have a minimum width of 100mm and a maximum width of 220mm when fitted to a buggy and a maximum width of 410mm when fitted to a Short Course vehicle.

1.7 All vehicle's must be constructed in such a way as not to have any variable (constantly variable gear drive) or multi speed gear boxes fitted, the section will only accept fixed single speed gearing whilst the vehicle is run on the race track, multispeed systems can not be locked into a single speed

1.8 2 WHEEL DRIVE BUGGY

- Shall have an overall maximum length of 820mm and a minimum weight of 8Kgs.
- Will have a wing that is no greater than 300mm by 140mm and will not overhang by no more than 150mm. (Over hang measured from the middle of the rear drive shaft to the rear edge of the rear wing).
- Will have a width, with tyres fitted of no more than 480mm when under full compression. It will also move freely in the size box.
- When fully compressed should have a height no greater than 360mm.
- Will have a fuel tank that holds a maximum of 800cc of fuel.
- Shall have a maximum engine of 26cc (1.5866 Cubic Inch).

4 WHEEL DRIVE BUGGY

- Shall have an overall maximum length of 820mm and a minimum weight of 8Kgs.

- Will have a wing that is no greater than 315mm by 140mm and will not overhang by no more than 230mm. (Over hang measured from the middle of the rear drive shaft to the rear edge of the rear wing).

- Will have a width, with tyres fitted of no more than 480mm when under full compression. It will also move freely in the size box.

- When fully compressed should have a height no greater than 360mm.

- Will contain a fuel tank that holds a maximum of 800cc of fuel.

- Shall have a maximum engine of 30cc (1.8307 Cubic Inch).

1.9 SHORT COURSE

- Shall have an overall maximum length of 1000mm and a minimum weight of 14Kgs.

- Will have a Minimum width of 480mm, Maximum width, with tyres fitted of no more than 600mm when under full compression. It will also move freely in the size box.

- Shall have a minimum wheelbase of no less than 600mm (Axle Centres)

- When fully compressed should have a height no greater than 400mm.

- A bodyshell which covers the vehicles wheels must be fitted along with a full roll cage within the bodyshell.

- Will contain a fuel tank that holds a maximum of 1000cc of fuel.

- Shall have a maximum engine of 30cc (1.8307 Cubic Inch).

1.10 OPEN CLASS

- Shall have an overall maximum length of 1000mm.

- Shall have a maximum width of 1000mm when under full compression. It will also move freely in the size box.

- Shall have a maximum weight of 20Kg.

- Will contain a fuel tank that holds a maximum of 1000cc of fuel.

- Shall have a maximum engine of 30cc (1.8307Cubic Inch).

1.11 It is the drivers responsibility to ensure that their tank does not hold any more fuel than the class limit. Tanks will be checked randomly in the main A final.

1.12 All fuel tanks fitted to vehicles must be fit for purpose, commercially available and safe

for the desired use. It will be the driver's responsibility to ensure that their tank aligns to the capacity of the class they race in, any displacement material used should be safe and suitable for the purpose.

- 1.13 Engines must be air cooled single cylinder, 2 or 4 stroke piston engine and assembled in accordance with the appropriate build instructions issued by the manufacturers and engine tuners.
- 1.14 Only fuel that is available from any UK petrol station may be used, no Avgas or specialist racing fuels allowed. The only additive allowed is 2stroke oil.
- 1.15 All ignition must be mechanically fixed, only manual static adjustment is allowed. The flywheel can only have 1(one)pair of magnetic poles (i.e. one north and one south). There can only be a maximum of 2 coils (either a single combined LT and HT coil with the standard type ignition or two LT coils with the external ignition systems) working with the flywheel/rotor

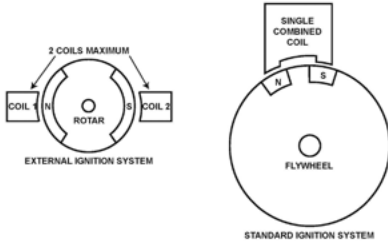

- 1.16 The following are not allowed: performance enhancing gases such as Nitrous Oxide, Fuel Injection, Boost bottles, Turbo or Super Chargers,
- 1.17 No battery-operated ignition allowed. Only a passive ignition system using R.P.M as the single input parameter is allowed.
- 1.18 Only open deck admission ports are allowed. The removal of material is free as long as the modified shape of the transfer\ admission port walls are in the direction of the cylinder bore at all times.

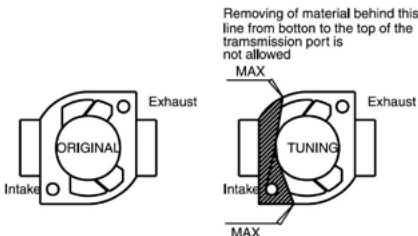

- 1.19 The cylinder block must be of a single casting, no independent liners or slipping liners are allowed.
- 1.20 The maximum number of admissions ports is limited to 4.
- 1.21 The crankshaft must be of split shaft configuration, with enclosed big end. No half crankshafts allowed.
- 1.22 An air filter must be fitted to the carburettor
- 1.23 The maximum venture diameter of the carburettor is limited to 13mm.
- 1.24 Heat sink heads may be used together with long reach plugs. Alternative ignition systems may be used providing they are not battery fed. All engines must be fitted with either a suppressor type plug or suppressed plug cap.
- 1.25 The exhaust must have a second muffler (if a two chamber exhaust is used) or be a three chamber type muffler. All three chambers must be designed so that the exhaust fumes will pass through and have to change direction twice to get the maximum possible noise reduction.
- 1.26 The design of that additional silencer is free, but with both systems together, the max. noise level must not be over our specified noise limits. The maximum permitted sound level for all cars/ classes is 81dB (+4db tolerance), measured at 1 metre above the track and no less than 10 metres from the car.
- 1.27 Any exhaust fitted shall comply with noise guidelines laid down by the host club or BRCA\MSA guidelines whichever is the lower. In practical terms no driver will be allowed to run with a car making enough noise so as to cause problems for the club on whose circuit the event is being run. Either kit standard exhausts (Zenoah can style) or 3 chamber exhaust systems are usually sufficient.
- 1.28 Open exhausts or pipes are not allowed.
- 1.29 The exhaust system to be mounted such that the manifold does not protrude further forward than the front window post and the system must run as close to the body as possible.
- 1.30 Stingers must not be mounted transversely (across) the underside of the rear wing.
- 1.31 Forward routed exhaust systems must not protrude from any forward facing part of the bodyshell.

- 1.32 Cars with uncovered exhausts must have shields in place covering the exposed hot areas. Un-silenced or "open" exhausts will not be allowed regardless of location.
- 1.33 The manufacturers Kill Switch must be made easy to both access and operate, access provided if necessary, by cutting a hole in the bodywork. A standard cut-out switch marker (available from the scrutineer if needed) to be affixed to the bodyshell within 1 inch of the location of the switch. All cars will be tested to see if their kill switch works on the start line and if not the car will not be allowed to run in that heat or final.
- 1.34 All LIFE\LIPO type batteries used as receiver batteries MUST be of the HARDCASE type, and are charged in accordance with manufacturer's instructions and within a suitable charging sack.
- 1.35 Tyres must be black except for sidewall detail.
- 1.36 Tyre additives are allowed but must not be added in the pit lane area.
- 1.37 Axles must not protrude the wheel or wheel nut by more than 1.5mm which ever protrudes the most.
- 1.38 Only Personal Transponders will be used to record laps.
- 1.39 Transponders must be fitted in such a way as to keep them as free from damage as possible, preferably inside the car as close to the ground as possible, as horizontal as possible, and away from any potential heat source. It is also recommended that they are not mounted directly above alloy or carbon fibre surfaces. It is the driver's responsibility to ensure the fitted transponder is working and laps are being recorded. The time keeper\race director will make the driver aware that there may be an issue and it should be rectified once the driver has marshalled and before they come out again.
- 1.40 All radio frequencies must be either 40 or 27 MHz, Am or Fm, or 2.4 GHz. If a driver books in on 2.4 GHz and has a problem then it is on the onus of the driver to arrange with Race Control to change to a 40 or 27 Mhz. crystal. Under these circumstances a driver cannot request a delay in order to change crystal. The driver must ensure that they have sufficient crystals so as not to clash with any other driver placed either above or below them.
- 1.41 All drivers on 40 and 27 MHz will be required to have available no less than 2 and preferably 3 frequencies (per car) and to be prepared to change to the frequency stipulated by the computer. i.e. drivers entering two cars will need a minimum of 4 frequencies available. Frequency changes can be requested on the day, (to cure interference etc.), but the heats will not be regenerated and the onus will be on the individual to consult with the Race Director about the change, to avoid a frequency clash. Note drivers should note that the computer, in generating the heats, tries to avoid the same two crystals being used in adjacent heats which are obviously beneficial. No changes to be made without the consent of the Race Director.
- 1.42 The use of electronic parts for "Traction Control & Breaking Control (ABS)" which can control the power of the transmission by means of a feedback system. Active telemetry transmission is prohibited. Sensors are only allowed for the purpose of passive data recording and not for adjusting the performance of the car whilst in motion. The reading of the data must be done with equipment, inside or mounted on the driver's radio. No external devices (i.e. in the pit/handheld by the mechanics) are allowed. The systems are not allowed to log the data.



GUIDELINES FOR REFEREES

Referees will be provided access to the race control computer (or monitor) where feasible for reading race positions and lap scores during the race.

At least one Referee shall be available where feasible to watch each Heat and Final, and should be watching for:

- Bad sportsmanship by drivers - i.e. deliberately impeding the progress of others by slowing down, crashing or hitting another car, corner cutting, driving recklessly to gain an advantage and/or being unable to properly control a car such as to cause a potential safety hazard.
- Cars in a dangerous condition - i.e. body not secured to chassis, causing damage to track, fixing or track markers, and a safety hazard to marshals.
- Jump starts
- Corner cutting (without any deliberate intent)
- Proper execution of any penalty awarded by a referee
- Bad driving
- Penalties can be issued as follows by the Referee, and be within these parameters for consistency:
 - Bad sportsmanship - disqualification from that Heat or Final, or disqualification from the Meeting at the Referee's discretion.
 - Cars in a dangerous condition - Black Flag (see rules 11.5, 11.7)
 - Jump starts - in qualifying for starting out of order - five sec penalty. In finals for moving before the start signal - a ten second penalty
 - Corner cutting - one lap penalty. Referees may also allow a driver to wait, and then tell the driver to re-join the race, to prevent any safety issues with other cars or marshals entering the track area.
 - Improper execution of a penalty - repeat of the penalty until it is correctly carried out to the Referees satisfaction. This counts as single penalty for purposes of disqualification.
 - Bad driving - stop/go penalty of up to 10 seconds, to be issued and supervised by the Referee.
- If three penalties are issued to one driver by the Referee during the Meeting (single day) the driver is disqualified from that Meeting.

Referees may warn drivers as to their driving conduct without issuing a penalty, and ensure that when a penalty is awarded, it is clearly stated as a penalty. The penalty must be marked on Race Control's copy of the heat/final results.



Precious Washers

We've got you covered

Service specialists (and sales)
of pressure washers,
vacuum cleaners and
floor cleaning equipment

**Nilfisk
ALTO**
works for you

Authorised
Distributor

**RAINBOW
SERVICE**

All makes and brands serviced
Over 95% on-site first time fix
No call out charge
Spares available ex stock

Pressure Washers

Vacuum Cleaners

Floor Cleaning

Precious Washers Stafford Ltd
Unit 24 Wolseley Court
Staffordshire Technology Park
Stafford, ST18 0GA
Tel: 01785227722
www.preciouswashers.co.uk



Nilfisk
trusted since 1906

Integrated Professional Cleaning



IPC Portotecnica

ON YOUR MARKS,

GET SET, SUBSCRIBE!

GET RACER DELIVERED THROUGH YOUR DOOR AND SAVE UP TO

47% + A FREE
GIFT



**SUBSCRIBE TODAY - GET 12 ISSUES FOR £27
& GET THE BEGINNERS GUIDE TO RC CARS WORTH £11.95 FREE!!!**

www.rcracer.com



Follow us on Facebook
facebook.com/rcracermagazine

Follow us on Twitter

[@rcracermagazine](https://twitter.com/rcracermagazine)



01525 222573



www.doolittlemedia.com



enquiries@doolittlemedia.com



Image courtesy of www.neo-buggy.net

Available on the
App Store

Google play

