

**1/10th ELECTRIC CIRCUIT SECTION RULES 2017**  
Version 2 – 14<sup>th</sup> January 2017

**Table of Contents**

1. SECTION CONSTITUTION
2. DEFINITION OF TERMS USED.
3. SANCTIONED EVENTS
  - 3.1 NATIONAL CHAMPIONSHIP
  - 3.2 CLUBMAN NATIONAL CHAMPIONSHIP
4. QUALIFYING SYSTEMS
5. FINAL SYSTEMS
6. CHAMPIONSHIP POINTS
7. INTERNATIONAL CHAMPIONSHIPS
8. RACE OFFICIALS
9. RACE PROCEDURES
11. MARSHALLING
12. PENALTIES
13. PROTEST PROCEDURES
14. CURTAILMENT OF EVENTS
15. GENERAL RULES
16. TECHNICAL RULES - TOURING CARS
17. TECHNICAL RULES GT10 & FORMULA 1
18. MOTORS
19. BATTERIES
20. RADIO EQUIPMENT

**APPENDIX:**

Appendix 1 – Global Body Specifications

## **1. SECTION CONSTITUTION**

**1.1** The Committee has the authority to provide clarification and interpretation of the section rules.

**1.1.1** If the rule clarification occurs outside of a BRCA sanctioned event, the section Committee must be in majority agreement of the rule clarification being made. The rule clarification must be communicated to all participants and published on the BRCA website at least 7 days before the race at which the rule clarification will first be enforced.

**1.1.2** If the rule clarification occurs at a BRCA sanctioned event, the present BRCA section officials must be in majority agreement of the rule clarification being made. Following the event, the whole section Committee must also be in majority agreement of the rule clarification, and the clarification must be published on the BRCA website, for the rule clarification to be enforced at subsequent BRCA sanctioned events

**1.2** At the discretion of the committee any driver, representative, mechanic or friend of a driver found to be under the influence of drink or drugs, or using abusive language or behaving abusively will be expelled from the meeting and may be subject to further restrictions on admittance to sanctioned meetings by the committee.

**1.3** Rule proposals for the Section AGM will be published on the official BRCA website. These proposals must be received by the Section Secretary on or before the 1st Friday in September using the standard template provided on the BRCA section website.

## **2. DEFINITION OF TERMS USED.**

**2.1** 'Committee' - This is the BRCA 1/10th Electric Circuit Section Committee as established by the BRCA Constitution. Committee decisions require a quorum consisting of at least 40% of the total committee membership.

**2.2** 'Sanctioned Event' – This is any race event for which the Committee has approved the date, venue and organiser. Sanctioned Events will abide by 1/10th Electric Circuit Section Rules at all times. Only Sanctioned events may use the letters BRCA in their title.

**2.3** 'Organiser' – This is the club or organization that hosts a Sanctioned Event.

**2.4** 'National' – This is a Sanctioned Event, the results of which count towards the BRCA 1/10<sup>th</sup> Electric Circuit National Championships.

**2.5** 'Race' - This can be any Practice Heat, Qualifying Heat or Final.

**2.6** 'Commercially Available' - Any item being accessible for purchase by anyone and therefore must be or have been available in UK retail outlets in reasonable volume at any one time.

**2.7** 'Track area' – This is the only area in which cars may be raced. It will be defined by barriers designed to contain cars in the event of an accident. Only Competitors, their mechanics and Officials will be allowed to enter this area.

**2.8** 'Blinky Mode' - This is any speed controller approved by the BRCA Electric Board that satisfies the Zero Boost specification.

### **3. SANCTIONED EVENTS**

#### **3.1 NATIONAL CHAMPIONSHIP**

**3.1.1** Venues to be chosen by an online vote of drivers who participated in at least the minimum number of counting rounds in the previous season.

**3.1.2** Event Entry: Each meeting will have a maximum of 11 heats. Entry fee £15 per meeting (£11 going to the host club. Any remainder, after booking fees, will go to the section funds). The host venue may charge up to £5 per driver for Saturday practice. Entries will open on 1st February each year

**3.1.3** Classes:

- 'Super Touring' for Open Modified Brushless motors (open choice from any Electric Board approved Brushless Motor list), with 2S LiPo battery.
- 'Pro Stock Touring' for 13.5t brushless motors with 2S LiPo battery and Open ESC.
- 'Stock Touring' for 13.5t brushless motors with 2S LiPo battery and Blinky ESC.

All classes must use approved bodies from the Touring Car body list.

**3.1.4** Event Schedule: There will be five, one-day meetings.

- Friday: Track Closed.
- Saturday: Practice (attendance optional).
- Sunday: 4 Qualifying rounds, 2 Finals rounds.

**3.1.5** Tyres: A single approved control slick tyre and a single approved control treaded tyre for the wet will be voted on from an approved list compiled by the section committee. This vote will take place annually by the competitors of the previous year's National championship. Competitors will be allowed to use the following number of tyres:

- Two sets of slick tyres.
- Two set of treaded tyres.

**3.1.6** Qualifying: Round by round qualifying will be used. Each competitor's two best scores will be counted.

**3.1.7** Finals: Overall final results (for trophy purposes) will be determined by adding the two final scores together. Ties will be resolved according to 5.2.2.

**3.1.8** The winner of the National Championship will be crowned the BRCA [year] [class] National Touring Car Champion.

## **3.2 CLUBMAN NATIONAL CHAMPIONSHIP – OUTDOOR**

**3.2.1** Venues to be chosen by an online vote of drivers who participated in at least the minimum number of counting rounds in the previous season.

**3.2.2** Event Entry: Each meeting will have a maximum of 11 heats. Entry fee £15 per meeting (£11 going to the host club. Any remainder, after booking fees will go to the section funds). The host venue may charge up to £5 per driver for Saturday practice. Entries will open on 1st February each year.

**3.2.3** Classes:

- '13.5t' for 13.5t brushless motors with 2S LiPo battery and Open ESC.
- '17.5t' for 17.5t brushless motor with 2S LiPo battery and Blinky ESC.
- F1 National Championship (to run at Clubman events), run to BRCA outdoor rules as published on the BRCA website.

All Touring Car classes must use approved bodies from the Touring Car body list.

**3.2.4** Event Schedule: There will be a maximum of seven, one-day meetings.

- Friday: Track Closed.
- Saturday: Track available for practice as published by the host club. Practice format to be determined by the host club, though it is recommended that classes with substantially different car speeds run in separate sessions.
- Sunday: 4 Qualifying rounds, 2 Finals rounds.

**3.2.5** Touring Car Tyres: A single approved control slick tyre and a single approved control treaded tyre for the wet will be voted on from an approved list compiled by the section committee. This vote will take place annually by the competitors of the previous year's Clubman championship. Competitors will be allowed to use the following number of tyres:

- Two sets of slick tyres.
- Two set of treaded tyres.

**3.2.6** Qualifying; Round by Round Qualifying will be used. Each competitor's two best scores out of a possible four will be counted.

**3.2.7** Finals: Overall final results (for trophy purposes) will be determined by adding the two final scores together. Ties will be resolved according to 5.2.2.

**3.2.8** The winner of each of the Clubman championships will be crowned the BRCA Clubman [year] [class] Champion.

## **GENERAL RULES**

**3.3** Event Entry: Competitors entering any BRCA Sanctioned Event must be a BRCA member. Membership cards or proof of membership may be required to be shown.

**3.4** Once booking in closes the number of finals is set, e.g. 55 rounded up to 60 = 6 finals for that class.

**3.5** A competitor may only enter one Touring Car class per meeting.

**3.6** All entry fees must be paid in advance and entries will not be accepted until payment is received. Late entries will be accepted after the normal closing date but the qualifying heat which late entry competitors are placed into is at the discretion of the Race Director.

**3.7** Junior drivers under the age of 17 on the date of the race they attend shall be entitled to a 50% reduction on the full entry fee for that race meeting.

**3.8** Entry cancellations must be notified directly to the Competition Secretary. Providing written notice is received at least seven days prior to the event, a 70% refund of the full entry fee will be provided.

**3.9** No Shows - Any driver not turning up at an event and not notifying the Committee in advance will have their entry withdrawn from the next event they are booked into. The entry will be reinstated on payment of a penalty fine of £10 or on receipt of a satisfactory explanation of the mitigating circumstances - the committee must receive this information at least seven days before the next event.

**3.10** All drivers must confirm their arrival to the race director before the end of open practice. Once qualifying begins, competitors shall stay in the race computer even if they decide not to race.

**3.11** Prize Giving: There will be a results presentation at the end of each event. The host club will provide trophies for the top 3 in each final. There will be trophies for TQ in each class. The top 3 juniors in each age category in each class will receive a junior placing trophy determined by their final position.

**3.12** The section will fund end of season Championship trophies.

**3.13** Track Requirements: Track width must be at least 2.4m at the narrowest point. The start line and timing loop must be identified on the track. There will be a designated 'pull-off' area and a designated 'stop-go' area.

**3.14** Applications to host a Sanctioned Event must be received by the 1st September. Applications must include full details of the venue, including: pitting area, toilet facilities, rostrum design, race control facilities and policy for camping/caravans. Details of standards required can be obtained from the Section Secretary.

**3.15** The calendar for all Sanctioned Events will be decided by the Section Committee and published as soon as possible online following the online vote.

**3.16** The National and Clubman National championships will run each year between 1st April and 30th September.

#### **4. QUALIFYING SYSTEMS**

**4.1.** The start of each qualifying heat will use a 1 second stagger between cars, with the order being determined numerically for round 1 and then by FTQ in subsequent rounds.

Cars not at the start line once the 30 second countdown has begun, or not setting off when their number is called, will start in numerical order when all the other cars have left. If for any reason a car does not start, then the race time for that car will begin automatically when one of the other cars has completed its first timed lap.

**4.2.** Round by Round qualifying awards points for each competitor's position in each qualifying round individually. The highest qualifying position in each round will score one point; second place will score two points, third place three points and so on.

**4.2.1** In the event of a tie on total points, the competitor with the BEST round score will be awarded the position (using all counting rounds until the tie is broken). If they are still tied then (from any of their counting rounds only) the fastest time will be used.

(Example) A score set [1,3] beats a [2,2]. If both competitors have a [2,2] but competitor A has a fastest time of 19-301.11 and competitor B's fastest is 19-304.55, then competitor A will win the tie break.

**4.3.** During qualifying, if a competitor has their race time adjusted for any reason then the round positions will be re-calculated using the new race times.

## **5. FINAL SYSTEMS**

### **5.1 General.**

**5.1.1** Drivers with a higher grid position may claim their preferred space on the rostrum.

**5.1.2** Finals are to be run in the same order as qualifying rounds.

**5.1.3** In the event of cars arriving at the grid once the 30 second countdown has begun, the countdown should be stopped, offending cars placed at the back of the grid and the countdown restarted from the 10 second mark.

**5.1.4** Finals will use a grid start of two rows of cars spaced at 3m intervals on a staggered grid. The top qualifier is to choose their preferred side of the grid from which to start. This choice will be used for all subsequent finals of that class.

**5.1.5** Cars must start behind their grid line and with at least one front wheel within the confines of the width of the box.

**5.1.6** An audible signal will start each final.

### **5.2 Multi-Leg Finals:**

**5.2.1** Races will consist of 10 cars except for the lowest final which may run less. The winner of each final gets 1 point; the second gets 2 points and so on. Cars that do not start or are disqualified will be awarded last place in their final.

**5.2.2** In the event of a tie on total points the competitor with the lowest counting final round scores will be awarded the position. If they are still tied then the competitor with the most laps completed in the fastest time from any of their counting final rounds will win the tie. Example: A [1,3] beats a [2,2]. If both have a [1,2] then the best laps/time from counting final rounds will be used to break the tie.

### **5.3 Single Leg Finals:**

**5.3.1** Races will consist of 10 cars except for the lowest final which may run less.

**5.3.2** The fastest time in the final will be awarded 1st position and so on down to last place. In the event of a tie the competitor with the best grid position will be awarded the position.

### **5.4 'Reedy Race':**

**5.4.1** Races will consist of 8 cars per race.

**5.4.2** Eight races per driver.

**5.4.3** Drivers should not race each other twice.



## **6. CHAMPIONSHIP POINTS**

### **6.1 National Championship**

**6.1.1** Each leg of the finals will count as a separate championship round (e.g. 5 events with 2-leg finals = 10 championship rounds). The winner of each A-final leg will receive 150 points, second 149, third 148 and so on down to last place at the event.

**6.1.2** All events declared by the committee as counting towards the championship will be used in the calculation of championship scores. A competitor may consider their best scores from 50% of the events declared, plus one, with halves rounded down.

**6.1.3** In the event of a points tie in the Championship, only results from the competitors counting championship rounds will be used to break the tie. The following order to break the tie will be used until a decider is found:

A) The highest round score will be considered (and so on down if required) until one driver has a higher score than the other (150 beats 149 etc).

B) The qualifying positions will be compared until one driver has a higher grid position.

C) The number of first, second, third etc round-by-round scores (the counting round scores) will be compared until one competitor has a better round score. If this fails to break the tie, the position will be shared.

**6.1.4** Two junior championships will be run per class:

- Under 13 - Under 13 years of age on or before 1st October of the current championship year
- Under 17 - Under 17 years of age on or before 1st October of the current championship year

## **6.2 Clubman Championship**

**6.2.1** Each leg of the finals will count as a separate championship round (e.g. 7 events with 2-leg finals = 14 championship rounds). The winner of each A-final leg will receive 150 points, second 149, third 148 and so on down to last place at the event.

**6.2.2** Overall Clubman championship winner and any potential tie breaks will be calculated using the rules set out in 6.1.2 and 6.1.3.

**6.2.3** Two junior championships will be run per class:

- Under 13 - Under 13 years of age on or before 1st October of the current championship year
- Under 17 - Under 17 years of age on or before 1st October of the current championship year

## **6.3 General**

**6.3.1** At all BRCA Championship meetings, up-to-date championship positions should be displayed. A copy of the BRCA rules must be available

## **7. INTERNATIONAL CHAMPIONSHIPS**

**7.1** Team selection for international events will be based on the previous year's national championship results, subject to those being eligible sending the section the entry fee required to enter that competition. If a competitor who is eligible cannot or has not sent the entry fee by the 1st February, the next eligible person on the list will be asked if they wish to attend. Once entry has been confirmed there will be no refunds for cancellation, if a competitor withdraws from an event and a suitable replacement found, the replacement competitor will reimburse the withdrawn competitor's full entry fee.

**7.1.1** There will be two wild card entries left open to be selected by the Committee.

**7.2** If the BRCA has any Official Team Clothing available, all competitors representing the BRCA at any international event, must wear this clothing for any Opening Ceremony.

## **8. RACE OFFICIALS**

**8.1** A Committee member will be appointed as the BRCA Steward for the meeting; the Steward will have overall authority regarding compliance to the rules and regulations and may be called upon to resolve any dispute.

**8.1.1** A Race Director or Timekeeper must be present at race control throughout the timed heats and finals at national events. Unless otherwise stated the race director will also act as referee.

**8.1.2** A Technical Officer who will check that technical and eligibility rules are upheld will be available at national events.

**8.1.3** A Timekeeper will check that the timing equipment is operational and that all races have started and finished in accordance with the rules.

**8.2** Referees may be used for qualifying heats and finals. Referees will be selected by the BRCA committee.

**8.3** The Referees will monitor driving standards and competitor behaviour.

**8.4** A Referee's decision is final and may not be protested.

## **9. RACE PROCEDURES**

**9.1** The maximum number of cars per race shall be 10. Finals and grid positions are to be determined by a driver's final qualifying position.

**9.2** Competitors who have raced in the National championship in the past will be graded on their previous % championship grading assuming that they are racing in the same class. Drivers who change class will have a 15% decrease applied to their % if changing class. New drivers to the championship will be graded at 1% when they enter their first meeting in the championship (it is at the committee's discretion to waive this in exceptional circumstances). If the driver has not raced in the championship for 3 seasons then they will be classed as a new driver.

**9.2.1** Driver grading will be based on championship position counting half plus one (with halves rounded down) of the completed rounds.

**9.3** The Race duration will be five minutes, plus last lap allowance.

**9.4** In severe weather conditions the Race Director is responsible to ensure that the track is in a suitable condition to race on.

**9.5** Practice rounds will be controlled and limited to slots of no more than 6 minutes duration. The rostrum shall be cleared of drivers at the end of each slot. Drivers of different classes shall not practice at the same time. Control of this practice session is to be determined by the BRCA Committee.

**9.6** After each race, the competitor in that heat will have their cars placed into technical impound and assume assigned marshalling positions for the following heat. No other person is allowed within the track area (except officials) while the race is in progress.

**9.7** An AMB/MyLaps system is to be used for timing and results should be determined based upon the accuracy specified in the club handbook (recommended to be the same as published by the timing equipment manufacturer).

**9.7.1** Only Personal Transponders supplied by each competitor will be used to record laps.

**9.7.2** At all sanctioned events it is the driver's responsibility to securely fit the lap recording equipment to their car before the start of any race.

**9.7.3** Competitors using a personal transponder are responsible for ensuring that such equipment functions with adequate signal strength. If this equipment malfunctions, competitors may have their laps recorded manually providing that:

a) The transponder starts the race clock for that race.

b) An official is satisfied that the car was circulating during any missed laps.

c) If the personal transponder does not record a finishing time, then final lap(s) can be awarded at maximum lap time for the driver in that race, until the total race time has been reached.

**9.8** During a race, the only people who can pass any information to a competitor are the Race Director (or their assistant), Referee or commentator. Receiving information from an assistant will result in a loss of that heat/final time. Competitors may pass on information to each other on the rostrum regarding cars that have stopped on the circuit.

**9.9** Only the Race Director, Timekeeper or a Referee may call for a restart of a race within the first lap of the leading car. If a race is abandoned after the first lap of the leading car then time must be allowed for recharging.

**9.10** At the race end, when the cars have passed the finish line, and the finish signal has been given, the cars must pull off into the designated pull-off area, so as not to interfere with any other competitors. Failure to comply will result in a penalty.

**9.11** If a race is abandoned, only cars running at the time the original race was aborted will be allowed to restart.

**9.12** National Meetings can only be abandoned by a majority decision of the BRCA Committee members present.

**9.13** No active mobile phones are allowed on the drivers' rostrum nor are they allowed to be used within the track area.

**9.14** Any race or heat stopped due to race equipment malfunction or an Official's error will be re-run after a suitable delay.

**9.15** Any race notified by race control as being delayed from the published timetable to either qualifying or finals will receive a minimum of 15 minute's notice prior to assembling on the grid.

**9.16** BRCA Section to supply scrutineering aids for all National events.

**9.17** Clubs running National sanctioned meetings are encouraged to provide commentary at the meeting, to cover finals as a minimum.

**9.18** A club provided public address system is to be used.

**9.19** All race venues must provide suitable ladies and gents toilets that must be open from when open practice starts and until the trophy presentation has finished.

**9.20** A pegboard will be used during open practice for non 2.4GHz drivers.

## **11. MARSHALLING**

**11.1** Competitors will be expected to marshal the race after their own, with competitors in the last race of a round expected to marshal the first race of that round.

**11.2** Penalties will be applied for late marshalling or failure to marshal.

**11.2.1** Failure to or late marshalling is clarified as being any marshal not at the correct position when the first car leaves the start line or final grid (unless the marshal is under instruction from a race official)

**11.3** Drivers are allowed to provide a competent substitute marshal, but the Race Director must be notified and approve of any change first. Substitute marshals must be current BRCA members. The driver will be subject to any penalties incurred by their substitute marshal.

**11.4** Marshalls must have their hands free at all times.

**11.5** Marshalls must wear safe and sensible footwear that will not become detached when performing marshalling duties. (Open toe shoes or sandals are not acceptable).

**11.6** At sanctioned events it is not mandatory to marshal open practice sessions.

**11.7** Marshall points (posts) are carefully positioned by the event organisers, if any competitor feels that the marshal points are unsatisfactory, they must inform Race control.

## **12. PENALTIES**

**12.1** Referees are empowered to give driving and marshalling penalties. All other penalties will be given by the Race Director and/or BRCA Steward.

**12.2** Jump Starts in Finals: After the 10 sec. count-down to start signal has started, any car moving ahead of the Grid line before the official start signal will be penalised:

- Up to one meter - ten seconds
- More than one meter - one lap.
- Penalty to be applied after the race has finished.

**12.2.1** If there are multiple 'jump starts' at the start of a Final, the referee can call for a restart and may decide not issue any penalties arising from the original start.

**12.3** Driving Standards; for a first offence the Referee will normally issue a clear warning. The Referee will clearly announce any penalty and record it on the published results for that heat/final. At the Referees' discretion, penalties can be incurred for bad driving and/or corner cutting with any one of the following, depending on the severity of the offence:

- Official Warning
- Stop-Go penalty
- 5 or 10 second penalty
- 1 lap penalty
- Disqualification.

**12.3.1** A driving penalty of one lap deduction may be awarded if any car continues to circulate the track after having received the finish signal, and especially so if that car in any way interferes with a competitor still racing.

**12.3.2** The Stop-Go penalty area must be well defined and in a position that is practical to operate.

**12.4** Failure to or late marshalling in qualifying will receive a penalty of loss of your best points score from qualifying.

**12.4.1** Failure to or late marshalling of a final leg will receive a penalty of loss of your best points score from the finals.

**12.4.2** A second marshalling infringement during the same event will result in disqualification and the allocation of 1 championship point for that event.

**12.4.3** All marshals must remain on their marshalling points until released by the following marshal or the race director. Failure to do so will be classed as failure to marshal.

**12.5** Any driver who ignores a warning or penalty issued by the officials will be disqualified from the race.

**12.6** A driver will be permitted a maximum of three penalties per event, for a 4th infringement they will be disqualified from the event and allocated 1 championship point for that round.

**12.7** The Referees' will not give a penalty for accidental corner cutting provided sufficient time is spent stationary so that no advantage is gained.

**12.8** Any penalty incurred for any reason will be carried into any subsequent re-run.

**12.9** Competitors exiting or entering the rostrum platform area while a race is in progress will be disqualified from that race. Race 'in progress' is clarified as from: - 'when the first car is started (all cars in Finals)' to 'the race is declared over'.

**12.10** Any failure to present the car to scrutineering, before/after the race in which the car has raced, or any failure to meet the technical and dimensional requirements of these rules before or after a race will result in the loss of that race time.

**12.11** Where post-race scrutineering is used as a method to mark the allocated tyre allowance for the meeting, and the competitor registers on the timing computer without presenting the car for post-race scrutineering, it will be assumed that the competitor has used one new set of tyres.

**12.12** Any competitor found to be using illegal equipment may at the Race Director's discretion be disqualified from the meeting and subject to appearing before the Committee, may be disqualified from participating in any other BRCA sanctioned event/s.

### **13. PROTEST PROCEDURES**

**13.1** A referee's decision (or non-decision) is final and may not be protested.

**13.2** Protests must be received by the Race Steward within 20 minutes of the end of the affected race; they must be on the official protest form (available from race control) with a fee of £25 which will be refunded if the protest is upheld. The Stewards decision is final.

**13.3** National events will have a Drivers Association Representative appointed, who will advise and (if required) represent any driver who has cause to query any official decisions or procedures.

**13.4** Any queries concerning official lap times and scores will be addressed to the BRCA Steward. A protest fee is not required. Any adjustments will be ratified with the Race Director and their decision in these matters is final.

### **14. CURTAILMENT OF EVENTS**

**14.1** In the event of any of the rules in this section being invoked these rules shall take precedent over any other rules which they may contradict.

**14.2** Non-national Sanctioned events may be abandoned by the Race Director in consultation with the Organisers. Results from any round can only be used if all races for that class in the respective round have been completed.

**14.3** National championship events can only be abandoned by a majority vote of the Committee members present after consultation with the Race Director. In the event of a National meeting being abandoned the following will be applied to determine the meeting results:

- After 1 round of qualification the meeting results would be declared on qualification positions after this round.
- After 2 rounds of qualification the meeting results would be declared using round by round points with 1 round counting.
- After 3 or 4 rounds of qualification the meeting results would be declared using round by round points with 2 rounds counting.
- After 1 round of finals, then the points will be awarded as normal for this round of finals, and a second set of scores for finals will be awarded based on the qualification positions. The final positions will be determined using both of these scores with tie breaks resolved in the normal method for finals.



In the event of the meeting being abandoned mid way through a round of qualification, the points for that entire round will be scrapped and results declared from the previous completed round as described above. If the meeting is abandoned part way through a round of finals, points will be awarded to finals that have been completed with any subsequent finals not run in that round will have points awarded as per qualification results.

**14.4.** Events abandoned when at least one qualifying round has not yet been completed will not be rescheduled and the total number of counting championship rounds will be reduced by one.

## **15. GENERAL RULES**

**15.1** It is each competitor's responsibility to ensure that their car meets all technical and eligibility requirements.

**15.2** The Section Committee are empowered to legislate at any time against any new equipment that in the opinion of the committee detracts from the essential skill of the driver controlling the car during racing.

**15.3** No car shall be constructed or presented for racing so as to be dangerous to persons or cause damage to competitor's cars or the track surface.

**15.4** The body and chassis must be securely joined at all times when the car is on the track.

**15.5** All cars must have a minimum of one identifying numbers to the front windscreen.

**15.6** Only one drive motor is allowed per car.

**15.7** Tyre treatments that can coat or damage the racing surface are specifically banned.

**15.7.1** The use of tyre treatments is at the race organiser's discretion. Notification of non-allowable tyre treatments must appear on the entry forms.

**15.7.2** The use of any oil of wintergreen-based product (i.e. smells of 'Deep Heat') is not allowed.

**15.7.3** No tyre treatments are allowed in wet conditions.

**15.8** The use of multiple-speed transmissions (gearboxes) is not allowed.

**15.9** Traction control is not allowed.

**15.10** Active suspension is not allowed.

**15.11** Gyroscopes are not allowed.

**15.12** Slipper clutches are not allowed.

**15.13** Suspension movement sensors are not allowed.

**15.14** Wheel speed sensors are not allowed.

**15.15** Tyre slip sensors are not allowed.

**15.16** Blinky ESCs must not be fitted with any device (active or inactive) that allows settings to be changed without physical contact being made with the ESC.

**15.17** Bodyshells: new bodyshells must be approved by the BRCA 1:10 Electric Circuit Chief Scrutineer. Approval lists to be published on the BRCA website.

Two lists will be maintained, "Touring Car" and "GT". To be added to the appropriate list, a body must be representative of a 'full size' Touring Car or GT (Racing version or Road going).

For the Touring Car list it must also meet the current Global Body Spec dimensional requirements (Appendix 1). Body shells will have a 5 year approval date, after which if still in production will have to be resubmitted. At all times body shells must be commercially available.

**15.17.1** Bodyshells may be added to the homologation list at any time subject to approval.

**15.17.2** Each manufacturer must pay a registration fee of £50.00 and anybody being submitted for approval must pay a levy of £10.00 per body. Any new bodies being submitted must have the part number moulded into the front windscreen.

**15.17.3** Bodies submitted for approval will be kept by the Section for future reference.

## **16. TECHNICAL RULES - TOURING CARS**

**16.1** No holes or slots are allowed on the body or wing, except for body post, aerial and transponder holes.

**16.2** Windows are to be clear or tinted, and must be clearly defined as windows.

**16.3** The main chassis cannot be changed during a race.

**16.4** Under body/chassis aerodynamic aids of any nature are not allowed. Smooth Lexan under trays may be fitted to waterproof the cars. Items to aid strength (including repairs), stiffness of the shell, or preventing the shell from becoming “tucked” are allowed.

**16.5** Details of all front and rear lights plus the main front grill must be clearly contrasted from the surrounding paintwork.

**16.6** Touring Car Dimensions:

Min (mm) Max (mm)

Wheelbase 250 270

Width (without body) 170 190

Width (with body) 175 200

Length (inc. body and wing) 360 460

Wheel dia (excl.tyre bead) 46 50

Wheel width inc.bead 18 26

Tyre width (across sidewalls) NA 27

Tyre diameter (when mounted on wheels) 52 67

Ride height (indoors only/checked on flat surface) 5 NA

**16.6.1** Maximum wing size including endplates: 190w x 40d x 20h (mm). Wings (excluding endplates) are to be of single moulded construction (no flat-packs/bend your own) and to be mounted directly to the body (no spacer between shell and wing), on the mounts provided at the back of the shell. All features (front splitter / bumpers) from the original moulding must remain on the shell.

**16.7** The minimum car weight, including personal transponders is 1350g.

**16.8** The use of tyre warmers is allowed but they may not be brought into the defined track area.

## **16.9 Control Tyres.**

**16.9.1** Tyres will be easily identifiable with a permanent external marking that can be used as a reference. This marking will include the manufacturer's name on the sidewall, plus the tyre compound and/or identification name.

**16.9.2** The tyre supplier must make tyres available to UK shops two months before the start of the championship, until the final round of the championship.

**16.9.3** The tyre supplier must make tyres available to UK shops such that shops can sell at the submitted retail price with at least a 33% profit margin.

**16.10** Any Competitor being suspected of not running the correct tyre build will have their tyres destructively checked at the end of the event. If the tyres are found legal, the competitor will have the full set replaced by the section.

**16.11** If any competitor is found using any other wheel/insert/tyre other than which should be used, they will be disqualified from that event.

**16.12** At sanctioned events all wheels/tyres must be marked, the process will be advised at each meeting by the appropriate officials. Markings must be clearly visible.

**16.13** Penalty for failure in scrutineering for a non-performance related failure, namely no grills or lights etc. will result in warning and not a time or points penalty.

## **17. TECHNICAL RULES - GT10 & FORMULA 1**

**17.1** Rules for the GT10 and Formula 1 Classes are to be maintained on section website.

**17.2** Classes for GT10 and Formula 1 class will be promoted by the controlling section committee by organising and promoting a BRCA championship subject to sufficient interest and subsequent entries being received.

## **18. MOTORS**

**18.0** At Sanctioned events, only motors that are currently homologated and listed by the BRCA Electric Board are allowed. Full technical data of homologated motors is available via the BRCA Electric Board Website.

**18.1** Open Modified Brushless Motors – any modified brushless motors approved by the Electric Board are allowed.

**18.2** 13.5t Brushless Motors – only 13.5 turn stock spec brushless motors approved by the Electric Board are allowed.

**18.3** 17.5t Brushless Motors – only 17.5 turn stock spec brushless motors approved by the Electric Board are allowed.

**18.4** 21.5t Brushless Motors – only 21.5 turn stock spec brushless motors approved by the Electric Board are allowed.

**18.5** Any driver found using an illegal motor will lose all lap scores up to that point. If found using an illegal motor for the second time the driver may be excluded from all sanctioned events for the rest of the season.

## **19. BATTERIES**

All Touring cars will be powered only by batteries approved and homologated by the BRCA Electric Board. Full technical data of homologated batteries is available via the BRCA Electric Board Website.

**19.1** Any driver found abusing their batteries at BRCA sanctioned meetings may be excluded from sanctioned events for the rest of the season and have their BRCA licence removed.

**19.2** The maximum voltage for a 2S LiPo is to not exceed 8.40 volts at any time. The maximum voltage of 1S LiPo is to not exceed 4.20 volts at any time.

**19.3** All LiPo/LiFe cells must be charged in a closed LiPo sack. A LiPo sack is defined as a receptacle designed for the purpose of charging LiPo/LiFe batteries and of a suitable construction as to contain a LiPo/LiFe fire.

**19.3.1** The heating of LiPo/LiFe cells is not allowed.

## **20. RADIO EQUIPMENT**

**20.1** Only 2.4GHz, 40MHz or 27MHz frequencies are allowed.

**20.2** Competitors using 27MHz or 40MHz must have a minimum of three frequencies available for competition use.

## APPENDIX: Appendix 1 – Global Body Specifications

### GLOBAL BODY SPEC ( GBS for Electric Sedans )

- |                  |                                 |
|------------------|---------------------------------|
| (A) = Max 10 mm  | (F) = Max 65 mm                 |
| (B) = Min 105 mm | (G) = Max 25 mm ( Max 3 posts ) |
| (C) = Max 85 mm  | (H) = Min 410 mm                |
| (D) = Min 90 mm  | (I) = Min 170 mm                |
| (E) = Min 65 mm  | (J) = Min 35 mm                 |

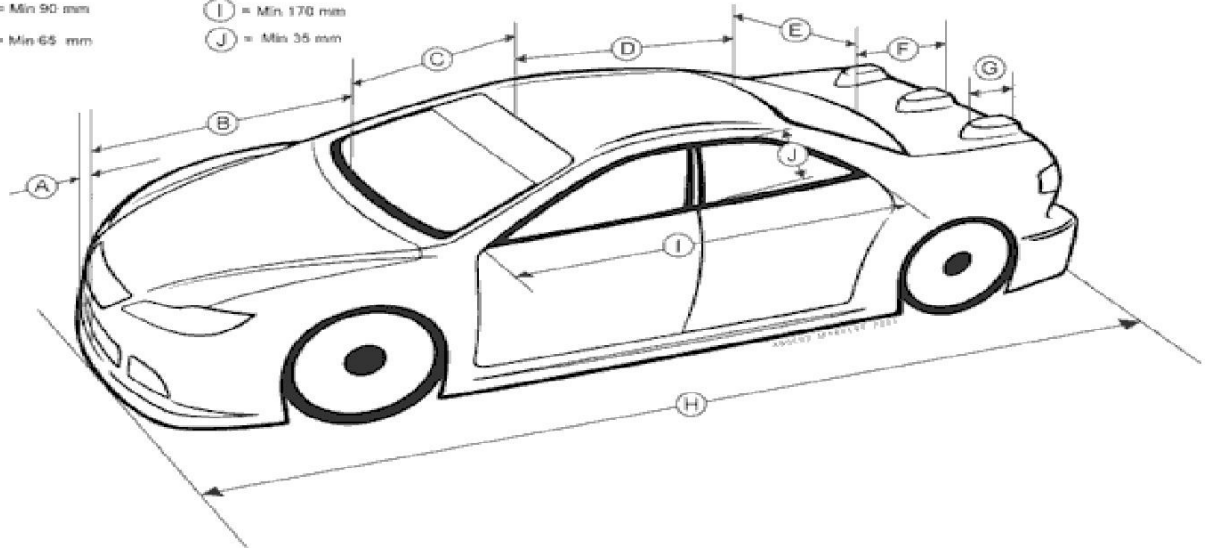

### GLOBAL BODY SPEC ( GBS for Electric Sedans )

- |                             |
|-----------------------------|
| (K) = Min 140 mm Max 155 mm |
| (L) = Min 110 mm Max 125 mm |
| (M) = Min 115 mm            |
| (N) = Max 195 mm            |

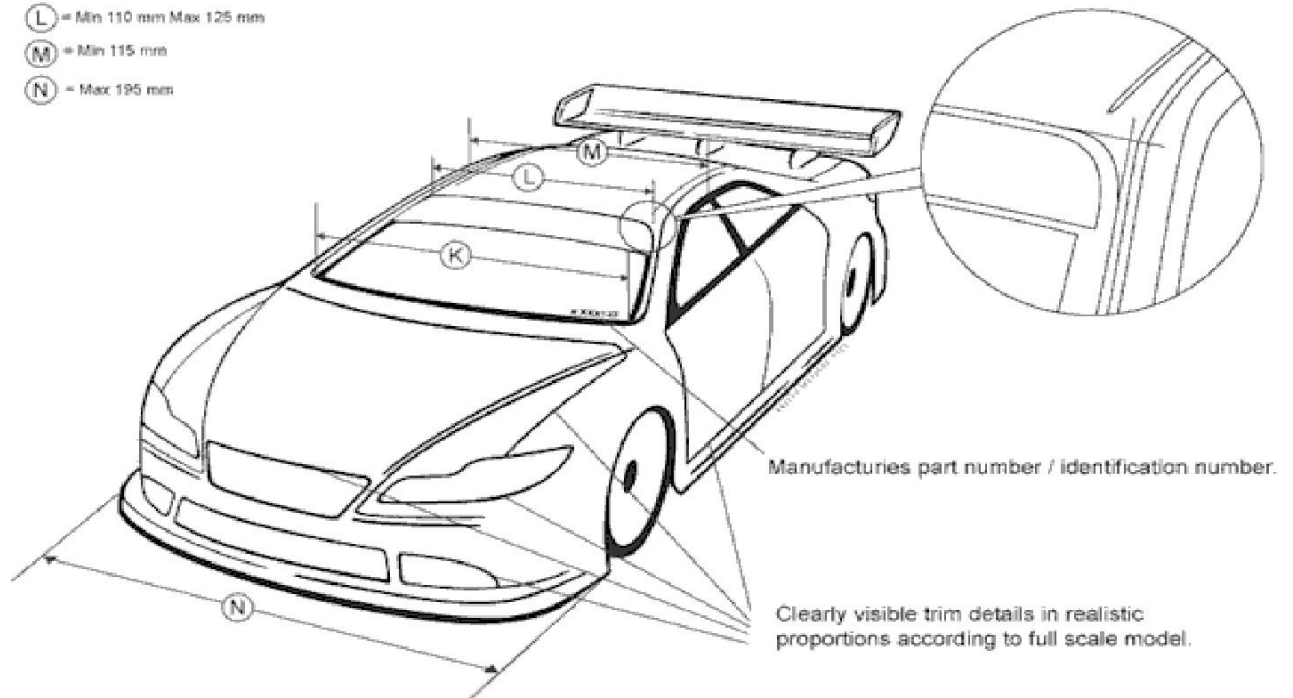

# GLOBAL BODY SPEC ( GBS for Electric Sedans )

- ⓐ = Min 150 mm
- ⓑ = Min 95 mm
- ⓒ = Max 10 mm
- ⓓ = Min 115 mm
- ⓔ = Max 35 mm

