



1:10 Electric Off-Road Rules 2022

Updated – 09.11.21.

NOTE: The possibility of problems due to Covid extending into 2022 cannot be foreseen. With this in mind, any resurgence of Covid could result in the number of events in any Sanctioned Championship Series being adjusted. To comply with any 'social distancing' that may still be required, some event procedural rules may need adjustment.

1. SECTION CONSTITUTION:

1.1 The Chairman manages the Section and takes the chair at all Section Committee meetings and at the Section AGM. He will consider all proposals and amendments made at such meetings, and whilst keeping in mind the best interests of the Section, will advise on the suitability of such proposals and amendments as he deems appropriate. He has the authority to provide clarification/interpretation of the Section rules.

1.2 Rule proposals for the Section AGM will be published on the official BRCA website. As required by BRCA General Rules, proposals must be received no later than five weeks prior to the Section AGM. Proposals received after that date will be for discussion only.

1.3 Voting at the Section AGM concerning International and National matters will be restricted to those members actively involved in such competitions and events.

No block or proxy votes will be allowed on any issue, one member-one vote will apply, as detailed in BRCA General Rules

2. RULE PRECEDENCE:

2.1 The BRCA Association General Rules detailed in the **2022** BRCA Handbook are mandatory for all Sections. Therefore the following Section rules and guidelines are additional to General Rules but do not take precedence.

2.2 The Section Rules are designed to cover all requirements for the National Series and other Sanctioned events. Regional events sanctioned by the Section should run to the same format, but are allowed to use variations of the following rules (which are underlined individually) :-

14.12, 15.10, 15.12, 15.14, 15.23, 15.29, 15.31, 15.32, 17.4, 17.5, 17.6.1, 18.2, 18.3, 19.1, 20.2, 23.4.1, 23.8, 23.11, 26.2.

3. DEFINITION OF TERMS USED:

3.1 'Committee' - The BRCA 1/10th Off-Road Section Committee as established by the BRCA Constitution. Committee decisions require a quorum consisting of at least 40% of the total committee membership.

3.2 'Sanctioned Event' - A race event for which the Committee has approved the date(s), venue(s) and organiser(s). Only Sanctioned events may use the letters BRCA in their title.

3.3 'Organiser' - The club or organisation that hosts a sanctioned event.

3.4 'National' - A race event sanctioned by the Committee, the results of which count towards the BRCA 1/10th Off-Road National Championships.

3.5 'Regional' - A race event sanctioned by the Committee, the results of which count towards a BRCA 1/10th Off-Road Regional Championship.

3.6 'Race' - A Qualifying Heat or Final.

3.7 'Commercially Available' - Where the term commercially available appears in BRCA documentation in regard to racing equipment allowed in 1/10th Off-Road Sanctioned events, it is defined as any item or items being accessible for purchase by anyone and therefore must be or have been available in UK retail outlets in reasonable volume at any one time.

New versions of tyres/compounds or tyres that have not been produced within an acceptable time, as deemed by Section officials, that are therefore not easily available to all competitors may be disallowed.

4. SANCTIONED EVENTS:

4.1 Off-Road Sanctioned events include the National Championship Series, Regional Championship Series, the British Winter Open Championship, Junior & Veterans' Championship and the Formula Championships. It is possible that further specific events could be sanctioned by the committee.

With the exception of any Regional Championship series, the Section committee reserve the right to cancel any of these events if the entry numbers at closing date would result in the event not being viable. Entries received after closing date may not be accepted.

- 4.2** The Junior & Veterans' Championship and the Formula Championships will follow the general format of National events. The British Winter Off-Road Championship may run to a variation.
- 4.3** Only Clubs/Organisers affiliated to the BRCA are allowed to run Sanctioned events.
- 4.4** Drivers entering these events must be a BRCA member, in order to compete.
- 4.5** At Sanctioned events, BRCA membership cards or proof of membership may be required to be shown at 'booking in' for the event.
- 4.6** Applications to host a National event, Junior & Veterans' Championship or Formula Championships must be received by the date of the Section AGM. Applications to host the British Winter Off-Road Championship event must be received by 1st March. Applications must include full details of the venue, including : pitting area, toilet facilities, rostrum design/suitability, race control facilities, local accommodation, policy for camping/caravans and advice on suitable control tyres if applicable. Details of standards required can be obtained from the Section Secretary. Sanctioned events can only be granted by the Committee. The calendar of events will be published in January of each year. Dates are subject to force majeure and the approval by the Committee of the venue and organiser.
- 4.7** The Committee are to ensure that National Championship venues and general facilities are of a suitable standard for National events.
- 4.8** Each Region will elect a Regional Representative. On election, that person will become a member of the Section committee.
- 4.9** Regional Reps. together with the Regions' Clubs, will organise a Regional Championship Series for each Region. The results of these Championships will be used as entry qualification for: The Jnr. & Vet. Championships and the Formula Championships.

5. THE NATIONAL CHAMPIONSHIP:

- 5.1** Eligibility: Any driver that is a BRCA member, (subject to rule 5.4). All Licence Grades are eligible.
- 5.2** The British National Championship is to consist of two separate classes for 2WD and 4WD cars. It will consist of six events for each Class, with the four best event scores per. class to count towards each Championship. (Subject to rule 19.3).
- 5.3** All entrants are required to be a BRCA member at the time of entry.
- 5.4** Entry to the National Series will be given to drivers in the following order (a-f):-
- a)** Priority in each class, will be given to drivers who enter a minimum of four events in that class, in the following order : F1, F2, F3, F4, F5. NOTE: Drivers that enter a min. of four events in a Class and receive confirmed places and subsequently cancel entries to a total of less than four events in the Class, may have their entry status revised as detailed (b) below.
- b)** Any remaining places in each class will be given to drivers entering less than four events in that class in the following order : F1, F2, F3, F4, F5.
- c)** Eligible entries not gaining places (from (a) & (b) above) will be placed on the National reserve list. Entries placed on the National reserve list at entry closing date will also be allocated in the same priority of (a) and (b) above, any entries having similar priority will be allocated in the order of date received. Any entries received after the official closing date will be allocated in the order of date received.
- d)** Entries sent after the official closing date (as stated on the official entry form), must be sent to the central booking address for arrival no later than four weeks before any event.
- e)** Entries made within four weeks of any event :- send direct to the event co-ordinator (Section Chairman).
- f)** Entries may be accepted on the day of an event.
- The order of priority of accepting entries is in the order of (a) to (f). Entries on the day or late arrivals may have to forego practice.
- 5.5** Competitors who officially enter a National event and fail to attend without prior notice being given by 18:00 on the Wed. before the event, may be removed (at the committee's discretion) from the normal seeding process at the next event attended. This procedure could be carried to the following year.
- 5.6** The minimum number of trophies to be awarded at a National event will be as follows: Top under 13 driver, Top F5 driver, Top F4 driver, Top F3 driver, Top F2 driver (subject to a minimum of three drivers competing), TQ driver and A Final winner. The presentations of the first 5 of these trophies will be made before the start of the second leg of the A final. The remaining trophies will be presented at the end of the event.
- 5.7** The National Championship will be to Modified Brushed and Modified Brushless Motor rules only.

6. THE REGIONAL CHAMPIONSHIPS:

- 6.1** Drivers of all licence grades are eligible to take part in a Region's Championship
- 6.2** The Regions are: East of England, Mid. South, Mid.East, North East, North West, Northern Ireland, Scotland, South East, South West and Wales.
- 6.3** The Section will sanction each Region to organise a BRCA Regional Series for both 2WD and 4WD classes. The Series will be used to determine Regional Champions.
- 6.4** Each Regional Series will determine a driver's licence grade for the following year.
- 6.5** Regional rounds will not be held on the same day as a UK National event.
- 6.6** Individual Regions will decide which class(es) of motors are allowed for their Regional Series, i.e., 27Turn, 19Turn, Modified Brushed and Brushless, Brushless Spec., or any combination

6.7 Any driver who:- claims, or attempts to claim points, in more than one Regional Series for the same class (2/4WD) in the same year, will be disqualified from all Regional Series points in that year for either/both Classes and will not be awarded a Licence grade from any of the results. Any driver contravening this ruling will be demoted to an F5 Grade for the following year, regardless of current grade or where it is obtained. It is the responsibility of the driver to ensure points are not scored in more than one Region per. Class and must inform organisers accordingly.

NOTE: Drivers can elect to compete in 2WD and 4WD in different Regions.

7. THE INDOOR REGIONAL CHAMPIONSHIPS:

Rule deleted, Nov. 2009.

8. THE BRITISH WINTER OFF-ROAD CHAMPIONSHIP:

8.1 Drivers of all licence grades are eligible to take part at the British Winter Off-Road Championship.

8.2 The Section will sanction a single British Winter Off-Road Championship event for 2WD and 4WD. This event will be self-financing.

8.3 Entry to this event will be on an individual basis using the official entry form on the BRCA website.

8.4 The British Winter Off-Road Championship will be run to Modified Brushed and Brushless Motor rules.

9. THE JUNIOR AND VETERAN CHAMPIONSHIPS:

9.1 All BRCA members are eligible, regardless of licence grade, who comply with the age definitions given below. First priority will be given to U13 and U16 classes, then the Veterans' class.

The Championship to be split into **four** age classes:-

- a) Under 13 years of age on 1st January of the current year.
- b) Under 16 years of age on 1st January of the current year.
- c) 40 years of age or over on 1st January of the current year.
- d) 50 years of age or over on 1st January of the current year.

There will be separate finals for U13 & U16 age groups at the Championships. The two age groups for Veterans will run as one Class in Qualifying and Finals but there will be an individual trophy for the two age groups.

9.2 The Jnr. & Vet. Championship will have separate classes for 2WD and 4WD.

9.3 The Jnr. & Vet. Championship will be run to Modified Brushed and Brushless motor rules.

In the event that 10 or less competitors are competing in any of the age Classes, that Class may be run to a format which differs to the established 'National' format (this could be a five race format using points from the best three races and no Final). Full details will be included on the entry form.

10. THE INTER-REGIONAL F2 CHAMPIONSHIP:

Rules deleted from 2016 and incorporated in New Rule 11 -- Formula Championships.

11. THE FORMULA CHAMPIONSHIPS:

11.1 This event will comprise of two separate Championships for :-

- a) Drivers holding an F3, F4 or F5 licence grade.
- b) Drivers holding an F2 licence grade.

Both championships will take place together at the same venue and date, with drivers qualifying through their Regional Series, with entries chosen in the order of Regional Championship results for each licence grade. Drivers must have competed at a Regional event(s) during the season to be eligible. Drivers will be allocated to the event applicable to their licence grade. Drivers can only enter one of the Championships.

11.2 Each Region is allowed to enter a team of their 'Top' drivers in each licence grade (F2, F3, F4, F5) in both 2WD and 4WD, as defined by their Regional Championship results. The 'Team' will be based on an equal number of drivers per. grade. If any Region cannot provide the allowed number for each licence grade in 2WD or 4WD, the Region can elect to enter more of an individual grade up to the total allowed for each Region. The number of driver's per. grade will be detailed on the Regional entry form, with a provisional number of 3 driver's per. grade per. Region.

11.3 For the F3,4,5 Championship event, eligibility is restricted to drivers holding an F3, F4 or F5 licence on the scheduled date of the event. (F1 and F2 licence holders are excluded).

Previous holders of an F1 licence are not eligible if they have held an F1 licence at any time within the five calendar years previous to the event.

11.4 For the F2 Championship event, drivers holding an F1 licence grade are not allowed, although they are allowed to compete and score points in their Region's Championships.

11.5 Both Championships' will have separate classes for 2WD and 4WD.

11.6 Both Championships' will be run to Modified Brushed and Brushless motor rules.

12. INTERNATIONAL CHAMPIONSHIPS:

12.1 Only current members of the BRCA can be selected as team members.

12.2 UK team members selected to represent the BRCA will be invited to attend by the Committee and will not need to apply.

12.3 The World Championship team is restricted to competitors that competed in the previous years National Championship for each Class individually and will be selected in the order of the previous year's National Championship results for each class individually. Members that enter the National Championship by the official closing date, that do not gain a place in a Class (2WD or 4WD) due to being on National Reserve Lists, would still be eligible subject to any places being available after those with a position in the Championship. The final date for competitor acceptance will be the 10th. December prior to the event.

12.4 The European Championship team is restricted to competitors that competed in the previous years National Championship for each Class individually and will be selected in the order of the previous year's National Championship results for each class individually. Members that enter the National Championship by the official closing date, that do not gain a place in a Class (2WD or 4WD) due to being on National Reserve Lists, would still be eligible subject to any places being available after those with a position in the Championship. The final date for competitor acceptance will be the 10th. December prior to the event.

12.5 Competitors accepting an offer of a team place at International events where entries are allocated to and paid by the Section (eg. EFRA, IFMAR), are irrevocably committed to paying the appropriate entry fees even if they find, at a later date, that they are unable to attend. Every attempt will be made to reallocate the place but the principle of liability will remain.

13. EVENT OFFICERS:

13.1 In addition to the appointment of a BRCA Steward as described in BRCA General Rule 5, Sanctioned events must have the following officials:-

Race Director - Responsible for the meeting overall,

Timekeeper - Lap counting and Finals arrangements,

Scrutineer - Checking that technical rules are upheld,

Race Administrator - Booking in, crystal changes, race numbers.

Additionally, National events must have the following officials:-

Section appointed Referees,

Drivers Rep. – Represents driver queries.

14. THE TRACK:

14.1 Safety procedures as detailed in General Rules 6, 8 & 9 must be adopted.

The rostrum and steps must be of sound construction. The design of steps should conform to recognised dimensions. Guard rails of suitable strength and position must be in place.

14.2 Tracks will be laid out so that there are no hidden areas when viewed from the driver's rostrum area.

14.3 Track markings must be placed to define the track lay-out and to minimise any corner cutting.

14.4 Tyres will not be used to define the track at BRCA National and Regional Sanctioned events.

14.5 At all National format events outdoors, tracks will be a minimum of 3 metres wide and minimum 130 metres in length.

14.6 At Sanctioned events (other than Nationals), it is recommended that tracks are a minimum of 3 metres wide, but must be a minimum of 2.4 metres wide.

14.7 The straight for starting finals, will be a minimum of 20 metres long, with no obstructions, including any form of jump, sudden rise or fall.

14.8 Start and finish lines must be marked. A 'penalty line' must be marked 2 metres in front of and parallel with the qualifying start line.

14.9 All tracks will have a designated 'pull-off' area for cars that have completed a race.

14.10 At all National events, there will be a designated 'stop go' penalty area.

14.11 All finals will have staggered grid starts at 2 metre intervals and two rows of cars. The top qualifier will choose which side of the grid they wish to start from.

14.12 The track will be closed to any kind of use, whether for race events or practice, by anyone, including the club's own members, for the whole of the seven day period immediately prior to the commencement of a National event, including all of the previous week-end. Any competitor proved to have contravened this ruling will be excluded from the designated National event or if proof is registered after the National event then all points from that event will be deleted. For Regional sanctioned events, the closure period (for any use) will be the whole of the five day period immediately prior to the Regional event. Regions can decide if this rule is adopted.

15. RACE PROCEDURES:

GENERAL

15.1 All BRCA Sanctioned events will be run to BRCA rules.

At National Championship events and End of Season Finals, 'drivers briefing' will be scheduled to take place before Practice and any use of the track.

15.2 The BRCA 1/10th Off-Road Committee will provide an automatic lap counting system at all National Championship events, End of Season Finals and the British Winter Open Championship.

15.3 The Committee will provide scrutineering aids for all National events. If cars are required to be scrutineered prior to a Heat/Final, any component parts that are changed after passing inspection will require such cars to be re-checked in the specification raced.

15.4 At all BRCA Championship events, a copy of the BRCA rules must be available.

15.5 A race commentary will be provided at all National events for at least the majority of the Finals.

15.6 Sanctioned Championship events must have individual lap times displayed for all competitors.

15.7 At all Sanctioned events it is the driver's responsibility to securely fit the lap recording equipment to their car before the start of any race.

At National events (including events using the Section timing equipment), competitors are required to supply their own Personal Transponder and are responsible for informing the organiser of the 'unique number' of this item. The competitor is responsible for ensuring that such equipment functions with adequate signal strength and is compatible with the event timing equipment as per. manufacturers specifications for the timing equipment. The Time Keeper is not required to perform a manual count or adjust times if a non-specified transponder is used.

Transponder malfunction procedure:-

a). If the Personal Transponder malfunctions and a lap(s) is not recorded, competitors may have their number of laps adjusted manually providing that :-

The transponder starts the race clock for the Heat (In Finals, this is computer generated) and records a finishing time for the Heat/Final and an official(s) is satisfied that the car was circulating during any missed laps.

Whilst this adjustment may be implemented more than once in an event, officials have the authority to refuse the procedure if a Transponder is continually missing laps in Heats/Finals. The competitor will be advised accordingly.

b). If the Personal Transponder starts the race clock, but does not record a finishing time, then officials may award a calculated finishing time and appropriate number of laps based on any recorded information available. The procedure of calculating the finishing time will only be adopted once for each competitor in any individual event.

c). If the Personal Transponder does not start the race clock, then no laps or time will be awarded.

15.8 All Heat and Final races will be of the same duration.

15.9 The Race duration will be a minimum of five minutes, plus last lap allowance.

15.10 The Qualifying Heats will consist of a maximum of ten cars.

15.11 With the possible exception of the lowest Final, all finals will be scheduled to consist of ten cars. Any driver electing not to take part in a Final will result in an empty space on the grid. (Drivers from a lower Final are not promoted upwards).

15.12 Subject to entry numbers allowing, there will not be less than six cars scheduled to take part in any heat. It follows that if any particular car does not start, then that heat could run with less than six cars.

15.13 Cars can only be driven within the confines of the designated track area. The use of radios' (including self-seeking frequency systems), to drive cars within the pits or spectator areas is not allowed unless permission is given by the Race Director. Competitors may only drive during their allotted race and then only from the platform of the drivers' rostrum. Spectators, pit-crew or competitors (not in a race), must not interfere with the progress of any driver within a race.

15.14 A penalty will be applied to any driver that enters or leaves the rostrum whilst a Heat or Final is in progress, unless instructed to do so by an official. Race 'in progress' is clarified as from :- 'when the first car is started (all cars in Finals)' to 'the race is declared over'.

15.15 All mechanics/pit-crew are to stay at their allotted positions until race over is declared or instructed otherwise by an Official.

15.16 At the first round of the National Championship, the top twenty one drivers from the previous year's championship will be seeded by lottery over the top three heats. For subsequent rounds, the current top twenty one drivers in the Championship, irrespective of licence grade, will be seeded by lottery over the top three heats. All other drivers will be seeded according to licence grade. Drivers of F3/4/5 licence grade that are known/proven to perform above their licence grade may have their seeding position adjusted.

Heat order at National events will be determined by licence grade with first heat on track in each qualifying round at each event containing the lowest Grade drivers, progressing up to the latter heats containing the highest Grade drivers. This heat structure will remain constant throughout all rounds of the National Series.

15.17 A suitable time warning will be given prior to the commencement of each race, as detailed in 15.18.

15.18 The starting and finishing procedure for each race must be explained at drivers' briefing including a demonstration of any tones made by the timing equipment if needed. At the start of each Heat/Final, the Time Keeper (assisted by the Race Director, Steward or Referee when needed) will determine when to "place drivers under orders" by a clear signal or announcement. Cars must then immediately go to on the Start line/Finals grid for placement and no more laps of the track are allowed. The final countdown will then commence.

15.19 Cars must not cross the start line before the start signal is given. Any movement off the start line after being placed "under orders", and before the start signal has been given, may result in a jump start penalty being awarded.

15.20 Only the Race Director, Timekeeper or a Referee may call for a restart of a race within the first lap of the leading car. Only the Race Director, Timekeeper or a Referee may abandon a race after the first lap of the leading car and then time must be allowed for recharging.

15.21 At the race end, when the car has passed the finish line, and the finish signal has been given, the car must pull off into the designated pull-off area, so as not to interfere with any other competitors. A driving penalty may be awarded if any car continues to circulate the track after having received the finish signal, and especially so if that car in any way interferes with a competitor still racing.

15.22 If a race is abandoned, only cars running at the time the original race was aborted will be allowed to restart.

QUALIFYING:

15.23 All Sanctioned events will use staggered starts for the qualifying rounds. The start order within heats for Round one can be chosen by random order, or alternatively can be based on Championship positions within each Heat. After the first Round the start order for subsequent rounds will be determined by each driver's fastest time.

At National events (and any events controlled by the National organisers), cars will be automatically called to the start-line and automatically called to start at an interval determined jointly between the Steward, Timekeeper and Referee. Timing/counting starts for each car separately the first time that car passes the timing loop. For any car that does not start as directed, the latest their individual clocks will be started is when any other car in the qualifying heat completes a full lap.

15.24 At National and Regional Series events, 4 Rounds of qualifying will be scheduled, weather/external circumstances permitting. Qualifying Rounds take precedence over Finals if it is foreseen that the full schedule cannot be completed. If 2 Qualifying Rounds are not completed, the event will be considered null and void.

At Non-Series events (eg. End of Season finals), 4 Rounds of Qualifying will be scheduled. Finals take precedence over Qualifying Rounds if it is foreseen that the full schedule cannot be completed (Rule 19.2 applies). If 2 Qualifying Rounds are not completed, the event will be considered null and void.

15.25 The Qualifying method can be FTD or Round by Round and the method will be announced at drivers' briefing. The Race Director may choose Round by Round qualifying when he decides that the track or the weather will not produce consistent conditions in every round of qualifying.

The FTD qualifying method uses a competitor's best single time to determine their place in a final. Any 'ties' which exist when all qualifying rounds have been completed will be decided by: the three fastest laps (ignoring the single fastest lap) achieved in each competitor's best single time will be added together. The competitor with the lowest total will be awarded the 'tie'. If this total fails to break the 'tie', then the fourth fastest lap will be considered and onwards until the 'tie' is broken. No times from any other qualifying rounds will be considered.

The Round by Round qualifying method awards points for each competitor's position in each qualifying round individually. Highest qualifying position in each Round will score zero (0) points, second place will score two (2) points, third place three (3) points and so on. (Regional events can amend this points system subject to software compatibility). Weather/external circumstances may prevent all scheduled qualifying rounds being completed, therefore points from each driver's best qualifying rounds are added together to determine a final qualifying position as follows :-

4 Rounds completed - Best 2 to count.

3 Rounds completed - Best 2 to count.

2 Rounds completed - Single best Round to count.

All other qualifying round scores will be discarded. Each Round has to be completed for any points to be awarded. If two or more drivers achieve the same time in any Round, the same points will be awarded to each driver and the next driver not tying will receive points relative to his position in the Round. In the event of a tie when the points from the 'counting' Rounds are totalled, the driver with the single best points within the rounds that counted will be awarded the tie. If this comparison fails to break the tie then the laps and times from the 'tying drivers' highest finishing positions will be compared. The driver with the fastest lap and time total will be awarded the tie. In the case of a continuing tie then the second best scores will be compared. In the unlikely event of a continuing tie at this point, the lap times from the heat that gave the highest finishing position will be compared and the fastest single lap will decide, then the second fastest and so on.

15.26 When Round by Round qualifying is used, if a driver loses or has his best round time adjusted due to incurring a penalty, then all drivers between his original position and adjusted position in that Round, will move up one place.

15.27 When Round-by-Round qualifying has been chosen, the Race Director may make changes to the track layout when these are deemed necessary due to bad weather and/or safety considerations. Any changes must only be made at the end of a completed round of qualifying. N.B. The tiebreak provisions of rule 15.25 still apply.

15.27.1 When Round by Round qualifying is used, competitors that decide to withdraw from the event once the event has started, must not be removed from the event. This ensures that Round scores already established are not affected.

Any competitor that withdraws from competing in a Final, will result in a 'blank' space on the Final grid. Competitors are not promoted upwards to fill the space, either from the specific Final or other Finals.

THE FINALS:

15.28 The Finals will be of the A to Z style.

15.29 All Finals must use a staggered grid start with spacing as 14.11.

15.30 The Top Qualifier of each class will choose which side of the grid they wish to start from. This choice will be used for all subsequent finals of that class.

15.31 All 'A' finals will run over three legs with the best results of two of the three legs to count. In terms of penalties incurred, each leg of the A Final is considered to be a separate race.

The Veterans Championship is recognised as a 'National type' event and will be allowed three leg 'A' Finals at the discretion of the organiser.

15.32 Drivers rostrum position for all Finals will be decided by Qualifying position. Higher grid position has preference and drivers may claim their due position via the rostrum referee.

15.33 There will be no delay allowance at the start of a Final for a driver that is found to be using an incorrect frequency.

16. MARSHALLING REQUIREMENTS:

16.1 Drivers will be expected to marshal during the race event. Failure to agree to this request, will be deemed as a voluntary withdrawal of that driver's entry from the event. Having agreed to perform marshalling duties, drivers can incur marshalling penalties.

16.2 Penalties will be applied by the Referees for poor marshalling, late marshalling or failure to marshal, as detailed in Rules 17.10, 17.11 and 17.12. Late marshalling is clarified as being any marshal not at the correct position when the first car leaves the Start line or Final grid (unless otherwise instructed by officials). Failure to marshal is clarified as being any marshal not at the correct position within one lap of the final car circulating. (unless otherwise instructed by officials).

16.3 A substitute marshal is allowed, providing that the substitute is a BRCA member, that they fulfil the marshalling duties adequately and that a Race Control Official has given permission. Only the designated marshals for any Heat/Final are allowed to marshal cars in that particular Heat/Final (a designated marshal can receive 'outside' assistance, if the car leaves the track confines, but the car must be passed to a designated marshal). At National events, only drivers competing in the event are allowed to marshal Heats and Finals, (this does not include marshals supplied by the host Club to cover unfulfilled places). If a driver at a National event cannot marshal due to a physical disability, a substitute BRCA member not competing in the event can be nominated, with the permission of a Section BRCA Official or the Race Director. The driver will be subject to any penalties incurred by their substitute marshal.

16.4 Only drivers who marshal the correct final(s) will score points in that round of the respective Championship unless specific permission is given by the Race Director.

16.5 Marshals must have their hands free at all times.

16.6 Marshals must wear safe and sensible footwear that will not become detached when performing marshalling duties. (Open toed shoes or sandals are not acceptable). Anyone failing to follow this instruction will not be allowed inside the Track Confines. If suitable footwear cannot be worn, then a substitute marshal must be provided. Failure to provide suitable Marshall Cover will be subject to penalties as covered by Rule 16.2.

16.7 Marshals must remain at their posts until replaced.

16.8 At National Championship events, it is not mandatory to marshal practice sessions.

17. PENALTIES:

17.1 Attention Is drawn to General Rule 12.

17.2 Any penalty incurred for any reason will be carried into any subsequent re-run.

17.3 Only Referees are empowered to give driving and marshalling penalties at National events. All other penalties will be given by the Race Director and/or BRCA Steward. All penalties given during Qualifying will be published with the end of Round results and penalties given in Finals will be published at the completion of Finals. If confirmation/discussion of any infringement is required, a Heat/Final may be placed 'under investigation' pending an eventual decision.

17.4 Simultaneous Starts in Qualifying - Cars being between the start line and the penalty line when the start signal is given will be penalised 10 seconds. Cars over the penalty line when the start signal is given will be penalised one lap.

17.5 Staggered Starts in Qualifying - Primarily:- Any car starting a race and continuing that race out of sequence of the announced start-order, or any car interfering with/or impeding a 'clean' start for another car during the starting procedures, will be penalised appropriately by the Referee/Start-line official. Cars being between the start line and penalty line before their number is called may be penalised 10 seconds if the Referee/Start-line Official judges a false start rather than movement due to any interference. Cars crossing the 2 metre penalty line before their number is called will normally be penalised 10 seconds, unless the Referee judges that they did not interfere with or impede any other car and did not continue out of 'announced start order' sequence. Cars will start when their race number is called. Cars not starting when called will immediately have their clock started by the Timekeeper.

17.5.1 Jump Starts in Finals – After the 10 sec. count-down to start signal has started, any car moving ahead of the Grid line before the official start signal will be penalised:- Up to 1 metre 10 sec. More than 1 metre will be 1 lap. If there are multiple 'jump starts' at the start of a Final, the referee can call for a restart and may decide not to issue any penalties arising from the original start.

17.6 At the Referees' discretion, penalties can be incurred for bad driving and/or corner cutting with any one of the following, depending on the severity of the offence: Official Warning, Stop-Go penalty, 5 or 10 second penalty, 1 lap penalty, disqualification. The Stop-Go penalty area must be well defined and in a position that is practical to operate.

If the Referee has decided to award a Stop-Go penalty but there is insufficient race time remaining to serve the penalty (eg. last lap), the Referee will instruct the Timekeeper to adjust the race time for the driver involved to reflect a 'served' Stop-Go penalty.

17.6.1 If a driver receives three Referee's warnings during an individual event the penalty will be seven places added to his event score. 2WD and 4WD warnings to be treated separately.

17.7 The Referees' will not give a penalty for accidental corner cutting provided sufficient time is spent stationary so that no advantage is gained (e.g., overall time)

17.8 Any driver who ignores a warning or penalties issued by the Officials will be shown the black flag. The car must immediately be removed from the track and the driver will lose that heat/final time.

17.9 Any car receiving assistance of an unfair nature (i.e., being pushed) to get to the finish line will be disqualified from that heat/final. Drivers taking an advantage, if being marshalled by a non-designated marshal will receive penalties as detailed 17.6

17.10 Penalties for poor marshalling will be as for driving penalties (17.6) and will be applied to the Heat/Final prior to the offence. (Except Heat 1 of Round 1 which will be applied to that Round time).

17.11 The penalty for late marshalling during Qualifying will be five places added to the drivers overall qualifying position under the FTD qualifying system. If the Round by Round system is used, it will be five places applied to the drivers final qualifying position when Qualifying is completed.

The penalty for failure to marshal during qualifying is the loss of fastest time under the FTD qualifying system. If the Round by Round system is used, it will be ten places applied to the drivers final qualifying position when Qualifying is completed.

17.12 The penalty for late marshalling in the correct Final(s) at a Sanctioned event will be seven places added to the final results for the event. The penalty for failure to marshal in the correct Final at a Sanctioned event, unless specific permission is given by the Race Director, will result in zero points being awarded at the event. The events points for other drivers are not adjusted. In addition, failure to marshal may also result in the penalised driver being disqualified from the next Round of that particular Championship (2WD or 4WD) or they will not be allowed to participate in any practice sessions at the next event they attend in the Championship (2WD or 4WD), which could be in the following year.

17.13 Competitors exiting or entering the rostrum platform area while a race is in progress during Qualifying will have ; seven places added to their overall qualifying position under the FTD Qualifying system, or seven places added to their best Round score under the Round by Round system. The adjusted positions of other drivers are as detailed in 15.26.

17.13.1 Competitors exiting or entering the rostrum platform area while a race is in progress during Finals will have seven places added to their overall event position. The positions or Championship points of other drivers will not be adjusted.

17.14 Any failure to present the car to scrutineering before/after the heat/final in which the car has raced, or any failure to meet the technical and dimensional requirements of the 1/10th Off Road rules before or after a heat/final will result in the loss of that heat/final time.

17.15 If the bodyshell and/or gear cover becomes loose or falls off during a race, the car must be removed from the track until the body and/or gear cover is securely re-attached.

17.16 Any competitor found to be using illegal equipment may, at the Race Director's discretion, be disqualified from the meeting and, subject to appearing before the 1/10th Off Road Committee, may be disqualified from participating in any other BRCA sanctioned event/s.

17.17 Subject to the findings of the Committee, the BRCA may take action against the manufacturer of illegal equipment.

18. SCORING:

BRCA Sanctioned Championships will use the following method of scoring.

18.1 Only BRCA members are allowed to score points in Sanctioned Championships.

18.2 Points will be awarded on finishing positions in finals. The winner of the A Final will receive 130 points, second 129 points and so on down to 130th place and beyond who will receive 1 point. At National and Regional Sanctioned events the driver who achieves TQ will be awarded one extra point to be added to his/her points for that meeting.

18.3 The A Final will consist of three individual 'legs', with points from the best two of three legs to count towards the result. The winner of any leg of an 'A' Final scores 1 point, continuing down to tenth who shall score 10 points. (No result in any leg gives 10 points). The 'A' finalist with the lowest number of points will be the winner of the event. In the case of a tie, then this will be decided by reference only to the two leg scores that counted. Firstly, by comparing the best single points scores, and then if still a tie the laps and times of each competitor's best points score will decide.

18.4 Positions tied by equal time (same time) in any Final will be awarded equal position and points, with the next placed position receiving 2 less points. If Finals have more than one 'leg', then any positions tied by equal time will be awarded equal points for the specific 'leg' of the Finals. No result in B to Z Finals, scores lowest points for the particular Final.

18.5 The driver with the highest points total at the end of the Championship is the winner.

18.6 If any scores are tied at the end of a Championship, the highest scores that counted will decide the tie. If a tie still exists, the next highest scores that counted will be compared and so on until the tie is decided. Only counting scores from the series will be compared, all other scores will be discarded. If this procedure does not decide the tie, the positions will be declared equal.

19. CURTAILMENT OF EVENTS:

19.1 National Championship events can only be abandoned by a majority vote of the Committee members present, after consultation with the Race Director. Other Sanctioned events may be abandoned by the Race Director in consultation with the Organisers.

19.2 At abandoned events, scores from any Rounds or Finals can only be used if all heats in the respective Rounds or all Finals have been completed. The overall qualifying positions after the last completed round at the time of abandonment, will count as final positions with the corresponding points being counted towards the Championship, providing a minimum of two rounds have been completed. Where Round-by-Round qualifying has been chosen the positions will be determined as per. rule 15.25.

19.3 At abandoned events where less than two rounds of qualifying have been completed, the event will be declared null and void and no results declared. National events will not be re-scheduled and any relevant championship qualification will be reduced accordingly (i.e. if there were 4 rounds to count from 6, then one abandoned event would mean there are 3 rounds to count from 5, etc.).

Regional events can be rescheduled (subject to 6.5) at the discretion of the Regional Rep. If an event is rescheduled to use a date not originally specified for any Class, then the number of events to count for the Regional Championship in that Class will be reduced accordingly, to allow competitors to achieve the minimum number of events using the original dates only.

If the normal Tie Deciding system of highest points does not achieve a result, then the highest Qualifying position at the last event in the Series for the Class will be used to decide the tie.

20. PROTEST PROCEDURES:

20.1 The Head Referee's final decision is final and may not be protested for any driving or marshalling infringements. Only the Head Referee can overrule another referee's decision.

20.2 The decisions of other officials may be protested. Protests must be received by the Race Director in writing with a fee of £20.00. The Race Director's decision is final. At BRCA National events, the Race Director's decision can be further protested to the BRCA Steward whose decision is then final. The protest fee is refunded if the protest is upheld.

20.3 National events will have a Drivers' Representative appointed, who will advise and (if required) represent any driver who has cause to query any official decisions or procedures.

20.4 Any queries concerning official lap times and scores will be addressed to the Timekeeper or Race Director/Steward. A protest fee is not required. Any adjustments will be ratified with the Race Director/Steward and his decision in these matters is final.

20.5 All finals' results will be published to allow competitors the opportunity to make objections within a maximum of 15 minutes following the display of any final.

20.6 No protests will be accepted after the prize giving ceremony.

20.7 At the Organisers' or BRCA Committee's discretion, or if three separate protests are received, providing £20.00 is put forward in each case, any motor may be stripped in the presence of a BRCA Official to prove its legality. If the motor is found to conform to (EB) rules in every respect, the competitor will be reimbursed the full cost they paid for the stripped motor.

20.8 Junior members may be allowed a neutral representative to protest decisions.

21. LICENCE GRADES:

The BRCA 1/10th Off Road Section will award driver licence grades as detailed below.

N.B. Where any percentage calculation results in a fraction, then the result will be rounded-up to the next whole number.

21.1 Demotion by a maximum of one grade is automatic if the driver has failed to re-qualify for the same or higher licence grade in the current year. Drivers that have achieved a 'top fifteen' place in the Off-Road National Championship Series since 1994 will not be demoted lower than F3.

21.2 Grades gained from the National Championships will take priority over grades from the Regional Championships.

21.3 Licence grades are calculated using the championship positions at the end of the National and Regional Series each year. All demotions and promotions will be effective from the 1st January of the following year and are maintained throughout that year. (e.g. a driver qualifying for an F2 licence from results in 2019 will be awarded that grade on 1st January 2020 and will remain an F2 for the whole of 2020).

NOTE: Due to government restrictions resulting in all 2020 & 2021 sanctioned events being cancelled, all licence grade promotions/demotions awarded for 2020 will also be used for all of 2021 & 2022.

21.4.1 From the NATIONAL SERIES:

F1 and F2 licence grades will be allocated on a percentage basis as follows:- the number of drivers that score points for the minimum number of events for the National Series (ie. 4 from 6 events) will be used as the base figure.

FORMULA 1 – The top 33% of the base figure is used against the final series' results to determine the F1 drivers, (2WD or 4WD separately).

FORMULA 2 – The next 17% of the base figure is used against the final series' results to determine the F2 drivers, (2WD or 4WD separately). The licence grade for these drivers will be known as F2N, but for seeding purposes is considered equal to Regional F2 Grades.

21.4.2 From the REGIONAL SERIES:

All competitors that enter an event(s) that count towards a Regional Championship, will be awarded a licence grade based on their overall position for that Championship (2WD or 4WD separately).

Regional formulae will be allocated on a percentage basis as follows:- the number of drivers that score points for the minimum number of events for a Region's particular Series (ie. 3 from 5 events) will be used as the base figure. Any drivers included in this base figure, that have gained their licence from the National Series of the current year (F1, F2 and demoted F1) will be subtracted from the base figure to give an adjusted base figure on which the calculations will be based. It follows that Regional licence grades can only be established when the results of the National Championship are finalised.

FORMULA 2 - The top 20% of the adjusted base figure is used against the final series' results to determine the F2 drivers. (2WD and 4WD)

FORMULA 3 - The next 30% of the adjusted base figure is used against the final series' results to determine the F3 drivers. (2WD and 4WD)

FORMULA 4 - The next 30% of the adjusted base figure is used against the final series' results to determine the F4 drivers. (2WD and 4WD)

FORMULA 5 - The final 20% of the adjusted base figure is used against the final series' results to determine the F5 drivers (2WD and 4WD).

21.4.3 Within BRCA CLUBS:

FORMULA 5- This licence grade may be awarded to any competent driver at the discretion of the club officials.

TECHNICAL RULES:

22. CONSTRUCTION – APPEARANCE:-

22.1 Cars entered for Off Road competitions will be reasonable representations of full size cars generally accepted as being suitable for Rallycross, Rallying, Trail and Desert races.

22.2 Open roll cage style cars will be permitted to compete if the entrant can supply proof that the car is closely based on a full size example.

22.3 The roll cage of any open car must enclose all the drive and guidance equipment.

22.4 Any commercially available 1/10th scale body shell may be used other than open-wheeled Formula 1 shells or sports racing shells.

22.5 In the case of open cockpit cars, a realistic driver figure must be included.

22.6 At BRCA Sanctioned events all cars must display 3 full sized BRCA issue numbers with one facing to the front and with one on each side in an upright position.

22.7 No cars may be raced without a bodysell being securely fitted at all times.

22.8 When initially entered in a meeting the body must be neatly finished.

23. CONSTRUCTION RULES – GENERAL:-

23.1 Two wheel drive cars (2WD) are those having only one pair of driven wheels on the same axle. Either the front or rear axle may be driven. Four wheel drive (4WD) cars are those having all four wheels driven.

23.2 The overall width of any bumper must not exceed the overall width of the front of the car including wheels. The bumper must be constructed of a resilient material such as plastic or rubber, with rounded edges and corners, and be of a design which will not cause personal injury.

23.3 The dimensions must conform to the following:-

Maximum length - 460mm inc. bumpers

Maximum width - 250mm at any point of suspension travel in a vertical plane.

Minimum weight - 1474grams for 2WD, 1588grams for 4WD complete and ready to race. The minimum weight(s) include fixed Personal Transponder but exclude Auto-powered (hand-out) Transponder.

A maximum of two wings can be used: one at front, one at rear. Maximum wing sizes are :-

Front – 127.0 mm wide with a chord of 63.5 mm max.

Rear -- 177.8 mm wide with a chord of 76.2 mm max.

Wing side-plates :- Height 50 mm max., length 80 mm max.

Vertical 'fins' included or attached within the wing area, must be no higher or lower than any side-plates. If no side plates are used, any vertical 'fins' within the wing area must not exceed 50mm maximum height overall (taken from highest point to lowest point of any 'fins', added to the wing topside and underside). Front or Rear bi-level wings are not permitted.

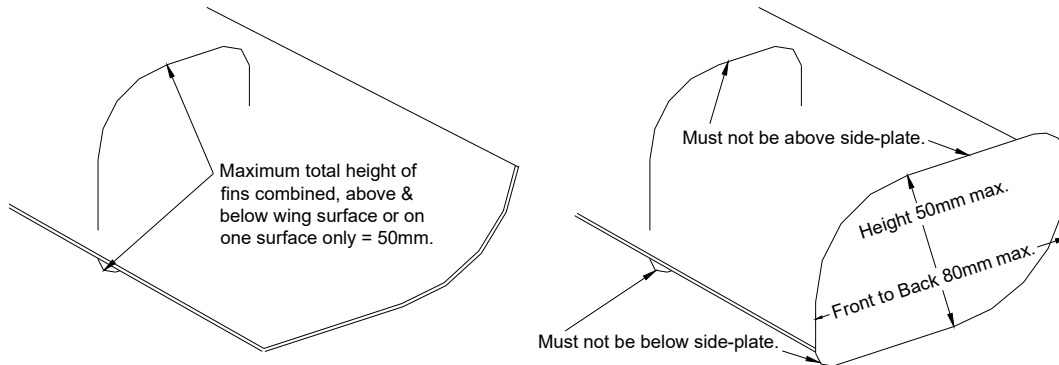

23.4 To be eligible to compete in the 4WD class, 2WD cars must race at 1588 grams minimum weight.

23.4.1 At National Championship events, 2WD cars (one driven axle) are not allowed in the 4WD Class events (this does not preclude any drive-train breakages during a heat/final). This can be adopted at other sanctioned events organised by the Section if deemed necessary. Individual Regions can decide if this rule is appropriate.

23.4.2 At National Championship events, any car competing in the 4WD Class must have effective drive to the front wheels. Any car which is designated as 4WD, must be able to complete a lap of the track with either the front or rear pair of drive-shafts removed, and all settings of the remaining drive-train as it will be raced, in a reasonable time frame. This can be adopted at other sanctioned events organised by the Section if deemed necessary. Individual regions can decide if this rule is appropriate.

23.5 Any type of speed controller may be used but it must be contained within the car and not protrude through the body shell. At National and Regional sanctioned events, Reversing Speed Controllers are not allowed or the reverse function must be disabled. Failure to comply would result in the car failing Tech. Inspection.

23.6 All open gears must be enclosed or protected during racing procedures, so as not to cause injury.

23.7 Wheels and tyres must conform as follows:-

No form of metal or plastic spike, tubes or anything similar can be attached to the tyres.

Maximum diameter allowed is 90mm front and rear.

Only commercially available wheels and tyres may be used (see 3.7).

Wheel sizes:

Min bead mounting diameter: 41.28mm.

Max bead mounting diameter: 55.88mm.

Bead mounting dimensions are measured at the Point where the internal tyre bead meets the wheel.

Max wheel diameter : 61.47mm.

Max wheel width: 38.10mm.

Wheel width is measured at the circumference of the wheel where the tyre is retained, the centre of the wheel maybe outside this dimension.

'Venting' holes in the internal rim of the wheel are allowed – maximum of two (2) holes, of maximum 6.0mm diameter.

(NOTE: The above wheel dimensions are the same as IFMAR and EFRA Rules. The original (and old) IFMAR Rules had imperial dimensions, hence the metric equivalent in later rules being to two decimal places that some manufacturers did not want simplifying).

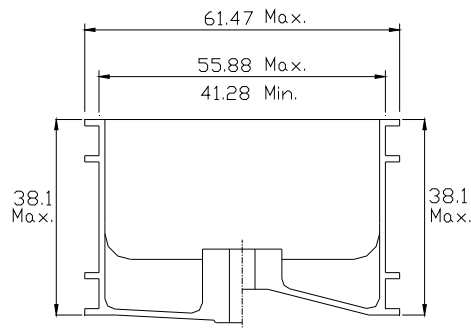

23.8 No sponge/foam tyres may be used. Foam tyre caps are not allowed but internal foam inserts are permitted.

23.9 No additives other than water will be allowed on any tyre. For gluing purposes only cleaning of the tyre bead where the tyre is glued to the wheel is allowed. No additives are allowed to be applied to any tyre insert. Excess of glue deemed to alter the performance of the tyre is not allowed.

23.10 Front or rear tyres constructed by 'cutting and shutting' are not allowed at Sanctioned events.

23.11 At Sanctioned events two types of control tyre will be adopted for the driven axle on 2WD cars and the rear axle of 4WD cars. The choice of tyres for the non-driven axle on 2WD cars and the front axle on 4WD cars will be free, subject to conforming to rule 23.7. The Section committee will approve the choice of control tyres. The make and type of the control tyres to be used at National events will be specified on the National Championship entry form and also in the confirmation document. There will be no restriction on the number or compound of tyres used.

23.12 The use of sensors fitted to wheels, lay-shafts or suspension units to aid traction control or active suspension is prohibited. The use of any third channel parameter on a receiver is limited to external power supply only (no signal circuitry allowed). All competitors at all events must also comply with BRCA General Rule 14 – Electronic Driving Aids.

23.13 The 1/10th Off Road Committee are empowered to legislate at any time against any new equipment that in the opinion of the committee detracts from the essential skill of the driver controlling the car during racing. Manufacturers, importers and others are therefore strongly advised to consult with the 1/10th Off Road Committee before investing in technology that may be ineligible.

23.14. Body shell holes/vents: The front and rear ends of the shell must retain some of the original profile of the two ends of the shell. Front and rear facing areas within the body shell surface which are 'marked' with the intention of removal to form "air scoops/ vents" are allowed to be removed, within a maximum dimension of 10mm in any direction regardless of the manufacturers marking. If no "marked" air scoops/vents are designed in the original mould to assist airflow to the motor or ESC, then material may be removed to a maximum of 10 mm. in any direction within a maximum square area of developed size 30 mm x 30 mm, in two places only. Windows are not allowed to be removed or include holes, other than for the purpose of the antenna.

23.15 It is the responsibility of all competitors to ensure that their car complies with all Technical Rules at all times during any Qualifying Heat or Final.

24. MOTORS:

24.1 Motors allowed at Sanctioned events fall into five classes: 27Turn Brushed, 19Turn Brushed, Modified Brushed, Brushless Spec. or Brushless Modified. The rules for all Sanctioned events/Championships will state which class(es) of motors are allowed (Sections 5 to 11).

24.2 All motors must conform to the descriptions and specifications found in the section entitled 'BRCA Electric Board' (EB). Motors can only be used if they are included on the BRCA (EB) homologation list(s) for the class(es) of motor allowed, at the time of the event.

25. BATTERIES:

25.1 Cars will be driven by cells/batteries with a nominal voltage not exceeding 7.6v, starting 1st April 2017. **The maximum charge voltage is 8.40v.** Cells/batteries cannot be replaced after a race has started.

25.2 The description, specification and types of rechargeable batteries approved for use in Off-Road Sanctioned events can be found in the section entitled 'BRCA Electric Board' (EB).

25.3 Cells and batteries can only be used if they are included on the BRCA (EB) homologation list at the time of the event.

25.4 Entrants must be prepared to open packs on demand of the race Scrutineer to demonstrate the eligibility of the rechargeable batteries.

25.5 All competitors at BRCA Off-Road sanctioned events must comply with BRCA Electric Board rules, in particular rules 3.6 to 3.10 inclusive.

25.6 LiPo/LiFe drive batteries must be charged in a 'Closed Lipo sack' at all times. LiPo sack is defined as a receptacle designed for the purpose of charging LiPo/LiFe batteries and of a suitable construction as to contain a LiPo/LiFe fire.

25.7 All competitors at any event must comply with BRCA General Rule 4 - Safety.

26. RADIO CONTROL EQUIPMENT:

26.1 All radio equipment must comply with BRCA General Rule 10.

26.2 Entrants will ideally be prepared to use any legal frequency, but will have at least three frequencies available at a Sanctioned meeting.