

# 10<sup>TH</sup> SCALE IC CIRCUIT 2022 HANDBOOK



**BRCA**  
BRITISH RADIO CAR ASSOCIATION

50

★ YEAR ANNIVERSARY ★



**BRITISH RADIO CAR ASSOCIATION**

To keep up to date with what's going on in the world of Radio Control Cars visit the BRCA main website at [www.brca.org](http://www.brca.org)

HOME CLUBS EVENTS AGM JOIN CONTACT BRCA COVID-19 INFORMATION [LOG IN](#)

**BRCA**  
BRITISH RADIO CAR ASSOCIATION

06  
SUN, FEB

HOME **SECTIONS** RESULTS RULES & DOCUMENTS SMART SEARCH MORE

**1/10 IC & GT8 BRCA Nationals Championship Finale**  
**Halifax 6th Round September 2021**

CHRISTOPHER JEFFERY | [1/10TH IC CIRCUIT](#) | 06 OCTOBER 2021



The final National and championship decider of the season took place at the premier newly resurfaced Halifax circuit in West Yorkshire.

[1/10 IC & GT8 BRCA Nationals](#) [1/10 IC & GT8 BRCA Nationals](#) [1/10 IC & GT8 BRCA Nationals](#)

**1/10TH IC CIRCUIT MENU**

- [10th IC Circuit Home](#)
- [10th IC Circuit Events](#)
- [10th IC Circuit History](#)
- [10th IC Circuit Results](#)
- [10th IC Circuit Documents](#)

**NEW TO 1/10TH IC CIRCUIT?**

[guide for beginners](#)

# Welcome to your new 10th IC Circuit handbook



This booklet has been created by the 1/10th IC circuit section. It is both useful for newcomers and seasoned campaigners alike. It is the responsibility of every member and event organisers to familiarise themselves with the rules of our section.

In this book you will be able to find:

## Construction rules:

This is where you will be able to find the rules that your car will have to meet to be able to participate.

## Procedure rules:

This is basically how the national days are formatted.

## Track information:

This is where you can find information on tracks facilities, camping and nearby hotels.

## Calendar:

This is where you will find the dates for this year's events.

For 2022 championships there will be 6 rounds best 4 to count towards your championship. Please remember that to enter a BRCA sanctioned event you must be a fully paid up member of the association and your mechanics must also be BRCA members. This year again we will run four National Championships.

200mm	220GT	GT8 Nitro	GT8 Electric
-------	-------	--------------	-----------------

There will always be people always willing to offer help and assistance at our meetings, so don't be afraid to ask any questions you may have.

We look forward to seeing you at one of our meetings.

## Bob Harley

1/10th IC Circuit Chairman

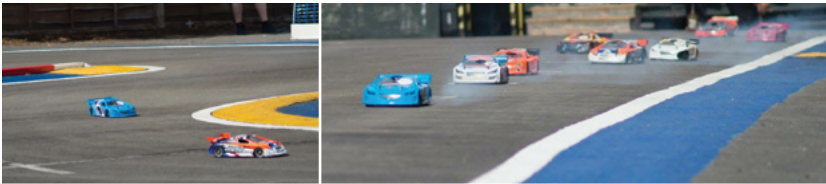

## How To Use This Handbook

This booklet is aimed at competitors or officials for the 1/10th IC Circuit class, enabling them to have the information required for the class at all times, however it should prove useful to all club racers too as we hope it will give the reader more information about our National series.

The information contained herein should be read in conjunction with the Association Handbook as the General Rules contained in the handbook apply to us all, at all events and in any circumstances take precedent over sectional rules. It is every member's responsibility to ensure they have read and understand the General Rules. Ask an executive official as appropriate for clarification if necessary.

### The application of the rules works thus:

The Association General Rules apply at all events we go to, including most club racing as we are all members of the association at all times, Sectional Rules (as in this book) apply at Nationals plus other events, e.g. regionals, as sanctioned by the section committee. Sectional rules do not apply at clubs, unless the clubs wish them too and it is entirely the Club's choice either way.

### Changing a rule

Every rule in this booklet and the Association Handbook was proposed and voted in by one of your fellow racers - none of the committees can simply 'make up' a rule. If you don't like a rule you can easily try and have it changed (though the first thought should be to find out the rationale of why one of your fellow racers proposed it in the first place perhaps?) If you're happy a rule needs changing get somebody else to agree with you - a seconder - and then write/email to one of the following people:-  
Section Rule to be changed - Section Secretary - who will liaise with you to ensure it's then voted on at their section conference.

Association General Rule including the Constitution - Association Secretary - who will liaise with you to ensure it's voted upon at the Association Annual General Meeting.

You should endeavour to be at any meeting where a rule change, you have proposed, is taking place as it will be discussed, possibly amended, plus you'll almost certainly be asked to elaborate on it.

### Summary

'The Rules' should be the easy bit of our sport, but they're not as we're all passionate about our sport and should want to have an input into how it's run, make sure you have your say, the Association works because people get involved and make a difference.

If you don't like how something is being done, you should offer to do it yourself, every Association official is a volunteer and they are doing a role because it needs doing. However, it is as much your responsibility to do that task as it is theirs - just that they volunteered to do it before you had the opportunity to offer to do it better.

Chairman's Introduction	3	Colchester	10
How To Use This Handbook	4	Cotswold	11
Intro / Committee & Contacts	5	Halifax	12
National Calendar 2022	6	Wombwell	13
Adur	8	Construction & Procedural Rules	13-19
Brookland	9	Setup sheet	20

BRCA 10th IC Circuit Section 2022 © BRCA 2016-2022. All rights reserved

Registered address: BRCA c/o. No 4, The Bungalow, Hopshort, Cheswardine, Shropshire TF9 2NS

The BRCA's consent must be obtained before any part of this publication may be reproduced in any form whatsoever, including photocopyers and information retrieval systems.



## Introduction

In the 1/10th IC Circuit section we race two different classes of nitro engine powered cars; 200mm touring and Sport GT cars. We also run GT8 nitro engine cars with .21 size engines and GT8 Electric powered cars. We race these cars at various on road venues around the UK for our National championship. The championship runs from April until September, consisting of 6 rounds with your best 4 results to count. Each round is run on a purpose built tarmac racing circuit.

When the National series isn't running, there are plenty of local race events happening at clubs around the country, enabling you to race all year round. Our cars are powered by 2.1cc racing engines for 200mm and Sport GT. GT8 nitro cars use 3.5cc engines. We use foam tyres for 200mm and Sport GT, our GT8 cars can only use rubber tyres.

As well as the various engine and tyre brands to choose from, there is also perhaps the more obvious decision of which car manufacturer to go with. There is a range of different brands available, including XRAY, Serpent, Capricorn and Mugen. Full details can be found on the manufacturer's websites.

## Race Procedure

Our nationals are held over a weekend with Saturday being an optional practice day which starts at 9am and the track shuts at 6pm (track dependent). On the Sunday we have a drivers briefing at 8:30 to address any safety concerns and the time table for the day. After the briefing we then go into a round of practice in heat order of 6 minutes of duration.

Next up are four rounds of qualifying heats with a 2 minute warm up to enable you to get your engine up to temperature and your tyres bedded in, which then rolls into the qualification heats. Your fastest round of qualifying will allocate your spot in the final.

### Chairman

**Bob Harley**  
10ic.chair@brca.org

### Assistant Scrutineer

**Neil Wallace**  
10ic.chscrutineer@brca.org

### EFRA Rep

**John Russell**  
john.russell@brca.org

### Secretary

**Nick Spratley**  
10ic.secretary@brca.org

### PRO

**Alex Thurston**  
10ic.pro@brca.org

### Safety Officer

**Mel Hartill**  
10ic.sofficer@brca.org

### Treasurer

**Muriel Russell**  
10ic.treasurer@brca.org

### Assistant PRO

**Devendra Mahatme**  
10ic.pro@brca.org

### Asst. Safety Officer

**Ian Hartill**  
10ic.asofficer@brca.org

### Chief Scrutineer

**Steve Brooke**  
10ic.chscrutineer@brca.org

### Entries Secretary

**Paul Dewsapp**  
10ic.entsec@brca.org



## NATIONALS

APRIL			
23rd - 24th	BRCA National Round 1	Halifax	
MAY			
21st - 22nd	BRCA National Round 2	Wombwell	
JUNE			
25th - 26th	BRCA National Round 3	Cotswold	
JULY			
16th - 17th	Open Regional Meeting	Wombwell	
16th - 17th	Open Regional Meeting	Adur	
AUGUST			
6th - 7th	BRCA National Round 4	Colchester	
SEPTEMBER			
3rd - 4th	BRCA National Round 5	Brookland	
OCTOBER			
1st - 2nd	BRCA National Round 6	Halifax	

This year's championship will be contested over 6 rounds at on road tracks with each driver's best 4 rounds counting towards their final championship place.

**Race Classes:** 200mm touring, 220GT, GT8 Nitro and GT8 Electric

**Race Entry:** To book into any of the events please book in via the BRCA website. The race fee is £25 per event per class, payable when entering online. Entries close at 21.00hrs on the Tuesday prior to the meeting, entries after that may be subject to a £5 late entry fee. Juniors will pay a proportion of the Entry Fee.



**Saturday:** Is open & timed practice.

**Sunday:** Six minutes practice in heats to start Sunday (track dependent), followed by four rounds of qualifying with fastest time of the day setting the grid for the A-Z Finals for each class.

All of the dates and venues have been agreed and confirmed with the host Clubs and will be subject to any Government Covid restrictions in force at the time.

The Open Regional Meetings are both held on the same date. The Meetings will be run alongside the 1/8th Circuit Section's (Points) event. Entry for these Meetings will be direct via the Club and the reduced entry fee will be £15.00 per car (NON Points race). More details to follow.

## EFRA EUROPEAN EVENTS

APRIL			
1st - 3rd	EFRA GP 1/10 IC and 1/8th Circuit	Italy	
MAY			
27th - 29th	EFRA GP 1/10 IC and 1/8th Circuit	The Netherlands	
JUNE			
13th - 18th	EFRA EC GT8 Nitro	Switzerland	
JULY			
25th - 30th	EFRA EC 1/10 IC (200mm)	Italy	
SEPTEMBER			
19th - 24th	EFRA EC 40 + (1/10IC 200mm & 1/8th Circuit)	The Netherlands	

# ADUR

## Model Car Club



### Address

Adur Recreation Ground  
Shoreham by Sea  
West Sussex BN43 5LT

### Website

[adurrc.org](http://adurrc.org)



### Contact

Ricky Slater 07881 633906  
[rickyslater26@hotmail.com](mailto:rickyslater26@hotmail.com)

### Camping

Available both Friday and Saturday night with a £5 donation to the club charity.



### Pitting

Enclosed grassed pitting area with a large area for camping, gazebo and tables and additional pitting. Compressor for car cleaning. Porta loos on site. Public toilet block 5 minutes walk.

### Catering

A burger van will be present on both days. McDonalds 5 minute drive away with pubs and restaurants 10 minutes walk away.



## Address

Brookland Raceway  
Romney Marsh  
Kent  
TN29 9TF



## Website

[southeastrccc.co.uk](http://southeastrccc.co.uk)



## Contact

[markgrant@radiocontrolracing.co.uk](mailto:markgrant@radiocontrolracing.co.uk)



## Pitting

Covered pits with electric, fully covered rostrum. Ladies, Gents and Disabled toilets available.

## Camping & Catering

Check with club.



## Address

Colchester Model Car Club CMCC  
Easthorpe Road  
Colchester  
Essex  
CO5 9EZ



## Website

Visit us on Facebook



## Pitting

Open grassed pitting area with a large area for gazebo and tables and additional pitting. Compressor for car cleaning. Permeant Ladies and Gents toilets on site.



## Camping

Available both Friday and Saturday night by agreement with the club.

## Catering

A burger van will be present on both days.

## Address

Cotswold Model Car Club  
Hanger/Woodside  
Haresdown Hill  
Kemble Cotswold Airport  
Cirencester  
GL7 6BA



## Website

[cotswoldmcc.co.uk](http://cotswoldmcc.co.uk)

## Contact

[secretary.cotswoldmcc@gmail.com](mailto:secretary.cotswoldmcc@gmail.com)



## Pitting

Fully covered pitting area with benches, tables and mains electric. Compressor in pitting area. The rostrum is covered.

## Camping

Must be pre-booked with club on their website. Available Saturday night £5 tent, £10 caravan.

## Catering

There are facilities trackside. Hot and cold food and drink are also served at the onsite AV8 restaurant.







## Address

Mendip RC Raceway  
Halifax Track  
Stainland Road  
Halifax  
West Yorkshire  
HX4 8LS

## Website

[halifaxtrack.co.uk](http://halifaxtrack.co.uk)



## Contact

John Russell  
07762 092512 • [john.russell@brca.org](mailto:john.russell@brca.org)

## Pitting

Fully covered pitting area with benches, tables and mains electric. Compressor in pitting area. Site open from 14:00 Friday but track closed. Toilet block with separate gents, ladies and disabled toilets.



## Camping

Available through the club.  
Available Friday and Saturday night,  
£7.50 per night.

## Catering

Cafe on site hot and cold drinks  
and hot & cold food available.



## Address

Wombwell Radio Control  
Kart Club  
Sports Stadium  
Station Road  
Wombwell  
Barnsley  
South Yorkshire  
S73 0BJ



## Website

[wombwelllargescalechampionship.co.uk](http://wombwelllargescalechampionship.co.uk)

## Contact

[trevorkersey@hotmail.co.uk](mailto:trevorkersey@hotmail.co.uk)



## Pitting

Hard standing or grass area available for gazebo and tables. Facilities are shared with South Yorkshire Karting Club with strict operating rules to adhere too. Rostrum is fully covered.

## Camping

£7.00 per night.





# 10<sup>TH</sup> SCALE IC CIRCUIT CONSTRUCTION & PROCEDURES RULES



**BRCA**  
BRITISH RADIO CAR ASSOCIATION

## 10TH IC CIRCUIT CONSTRUCTION RULES

- All cars must have a de-clutching device and have an operating brake capable of stopping the car and holding the car motionless with the engine running.
- The front bumper must be fitted to the car to the same shape of the bodyshell and material as supplied in any standard kit car. The bumper must not protrude outside the body nor shall it be cut down beyond the shape of the body. It should be constructed as to minimise injury that may result from being hit by a car.
- The car may be substituted during the race meeting if the heat or final is declared wet by the race director. The wet car must have been identified and marked as a wet car prior to the meeting start, cars may not be changed once any heat or final has started.
- Gearboxes up to two-speed only shall be used in all classes.
- Fully independent suspension will be allowed in all classes.
- The engine must be fitted with an unmodified exhaust system from the BRCA approved list.
- Fuel tank, fuel tube, and any external fuel filters are not to exceed a total capacity of 75CL and no loose inserts in the tank are allowed. It is up to the driver to check that they do not infringe this rule prior to racing. If the car's total capacity is found to be above this figure the driver will be disqualified from that heat or final.
- All wheels/tyres are not to protrude outside of the bodyshell.
- All types of tyre additives are prohibited from use in all classes. Anybody wilfully found using additives will be disqualified from the day's racing.
- An air intake silencer (e.g. approved INS box) must be fitted to the carburettor air- intake of all engines, with no internal modifications except for a 3mm hole at the base of the unit to allow water to drain. If the meeting is declared wet a substitute air filter may be used.
- All entrants in 1/10th IC National events must use a personal transponder compatible with the electronic race control equipment.
- The engines for both classes may be of any configuration and construction with front rotary valve two-stroke air-cooled induction type, with standard 1/4 UNF or conical (turbo) glow plugs permitted.
- No form of forced induction or any form of variable port timing is allowed. One additional gap or slit in the bottom (or skirt) of the piston is allowed. Additional slits or holes in the liner are allowed as long as they do not extend beyond the top of the piston when it is at the lowest point of the stroke. For the purposes of this rule, a hole is defined as being an aperture completely surrounded by material. Engine internal modifications are allowed as long as they are within the parameters of this rule.
- Fuel may only contain Methanol, Oil/ Lubricant and Nitro-Methane with maximum 16% nitro methane content. Verifying this fuel will be done using a floater called Nitromax 16, which is commercially available. Any driver using fuel found to be illegal will be disqualified from the race in question. If a driver is found to use illegal fuel on a second time at the same meeting he or she will be disqualified from the meeting.
- All measurements referred to in these sections are minimum or maximum values. All measurements for the motor dimensions are to be considered with 2 digits behind the decimal point, all other measurements 1 digit behind the decimal point. Measurements must be within their maximum or minimum values under all circumstances.
- Minimum weight limits in both classes shall include a personal transponder and the tank be empty of fuel. If the weight is found to be under the minimum weight, the driver will be disqualified from the heat or final.

## SPORTS GT CLASS TECHNICAL RULES

- **ENGINES:** Maximum engine capacity of 0.15 cu in (2.5cc) allowed.
- **WEIGHT LIMITS:** Cars must weigh a minimum of 1700grams.
- **CHASSIS/BODY DIMENSIONS:** Wheelbase - 280mm max. Overall length (incl. Wing) - 490mm max. Overall width (with body) - 250mm max.
- **2.4. BODYSHELLS:** Bodysells are to be 1/10th scale type GT. The body will have a closed cockpit with front windscreen and side windows. All windows must remain transparent. No open cockpit bodies are allowed, shells must be commercially available. No performance aids or additional spoilers are to be fitted to the bodies apart from one rear wing or as supplied as part of the body. If the meeting is declared 'wet' the bodysell may have additional water proofing aids made of a flexible material added/fixed inside the shell only.
- **WINGS:** Rear wing Cord Width End plate 55mm 233mm 55mm x 25mm.
- **TYRES AND RIMS:** All dimensions in mm.

	Max dia	Max width
Front wheels	51mm	33mm
Rear wheels	51mm	51mm
Front tyres	75mm	33mm
Rear tyres	80mm	51mm

NB. A tolerance of a further 1.0mm is allowed for tyre and wheel width.

## 200MM TECHNICAL RULES

- **ENGINES:** Maximum engine capacity of 0.12 cu in (2.11cc) is allowed with maximum of four (4) ports including the exhaust port. The carburettor shall have a maximum throat diameter of 5.50 mm.
- **WEIGHT:** Cars must weigh a min. of 1650grams.
- **CAR DIMENSIONS:** All dimensions in mm.  
 Wheel base: Min. 230.00, Max. 270.00  
 Width without body: Min. 170.00, Max. 200.00  
 Length inc. body and wing: Min. 360.00, Max. 460.00  
 Height to the top of the roof measured with a 10mm spacer under the chassis plate on level. Min. 120.0, Max. 175.00  
 Wing cord inc gurney strip (if fitted) 55.00.  
 Side dams: width 50.00 Side dams: height 35.00 Wing overhang (at rear) 10.00.
- **BODIES:** 200mm Touring Class any commercially available bodyshell intended for 200mm 'Touring cars' is allowed, provided the engine is contained within the bodyshell, and it satisfies the dimensions in rule. The rear of the body may not be cut higher than 50.00mm measured with a 10.0mm spacer under the chassis plate on a level. The body must be made from a flexible material and be painted properly. All windows must remain clear or be semi-transparent. Details of all front and rear lights, grills, air intakes and windows must be clearly contrasted from the surrounding pointwork. No parts of the car except the muffler outlet may protrude outside of the bodyshell when viewed from above. No parts of the car except the antenna, body posts and transponder may protrude outside of the bodyshell when viewed from the side. If the meeting is declared 'wet' the bodyshell may have additional water proofing aids made of a flexible material added/fixed inside the shell only.
- **CUT OUTS:** One cooling hole in the front windscreen, max. 60.0mm diameter. A hole is allowed directly above the engine cooling head for glow plug access with a max. diameter of 35.0mm. A re-fuelling hole may be cut in the roof, max. diameter 50.0mm; the centre of this hole must be the centre of the fuel filler cap viewed from above. Note cooling hole in front windscreen and re-fueling hole may not be combined. Minimum distance between holes of 5.0mm. Both front side windows and the rear window can be removed for ventilation. The rear side windows must remain intact. Small holes can be made for the body posts, transponder, carburettor adjustment and radio antenna, max. 10.0mm. The hole for the exhaust pipe must be of reasonable size. No other holes are permitted.
- **WINGS AND SPOILERS:** One wing and one spoiler may be mounted to any car (if the original full size car had more it is allowed to do the same). Wings and spoiler must be made from a flexible material. Wing and spoiler may not be fixed to the body with piano wire. It must be mounted to the body directly. Wing and spoiler must not protrude outside the maximum height and width of the body (including side dams). The height of the wing may be adjusted but the wing including side dams must not extend higher than the roofline. Rear wings must be mounted in the same place as was intended by the body manufacturer. The overhang must not exceed 10mm at the furthest point to be measured from the most rear point of the body. Side dams may be fitted but must be a reasonable representation of those fitted to the original car. They must fit in a rectangle with the measurements defined above and must not project above the height of the roofline. Wings (excluding side dams) are to be of single moulded construction (no flat packs/bend your own). Any Gurney strip (if fitted) must not exceed the width of the wing. The Gurney strip must not have an edge more than 5mm high.
- **BUMPER:** The front bumper must follow the body contour and must be constructed so as to minimise injury that may result from being hit by a car. The bumper must be made from foam rubber or a flexible plastic material.
- **AERIAL:** The aerial must be flexible. Carbon, metal etc. aerials are not allowed.
- **TYRES:** Tyres must be black except for writing on the sidewalls. Foam and/or rubber tyres can be used. Treatment of the tyres with additives is prohibited. Anyone found to be using additives will be disqualified from the meeting and have a one year ban from the section. Wheels must be fixed by a screw or nut.  
 Quick - change wheel systems are not allowed. No automatic systems to change the wheels allowed (just manpower).
- **TRANSMISSION:** 4wd and 2wd cars can be used without any technical restriction. The use of separate front wheel brakes except through the transmission is not allowed. Locking of one way bearing is allowed.
- **ROLLBARS:** Rollbars (roll-over bars) on Touring Car classes must be kept under the body.
- **DRIVER AIDS:** It is not allowed to use any electronic device for traction and/or braking control.

## GT8 NITRO TECHNICAL RULES

- All cars must be a reasonable likeness to a full-size GT car.
- All cars must have a de-clutching device and must have brakes capable of holding the car motionless with the engine running.

- Any part of the car may be changed during the race except the chassis, which may only be changed by permission of the committee.

## ENGINE / FILTERS/SILENCERS

- Engine capacity shall not exceed .21 and engines may not have more than 5 ports.
- Engines must be fitted with an approved INS box type air filter, modifications to INS boxes will only be allowed for wet weather use.
- Engines must be fitted with a suitable silencer/muffler, preferably one made by the same manufacturer as the engine being used, all exhaust outlets must point horizontally or below, and must be able to meet EFRA approved noise levels for racing purposes.

## FUEL SYSTEM

- Fuel tank capacity (including tank and any or all fuel pipes/filters) shall not exceed 150cc.
- Fuel used shall have a maximum of 25% by volume of nitro methane, and all fuels shall only contain Methanol/ nitro methane and lubricating oil.

## TYRES AND WHEELS

- Tyres and wheels used must only be of commercially available types, made for GT8 type cars, and must be of rubber slick or treaded type and must display original identification marks.

## DRIVE SYSTEM AND WEIGHT

- All cars must be of shaft drive construction (no belt drive systems to be used) and must be 4WD.
- Minimum weight of the car with everything included (except fuel) shall be no less than 3500 grams.

## BODYSHELLS / WINGS

- All bodies used must be of reasonable likeness of a full-size GT racing car, must not be modified by adding aerodynamic aids or parts not originally supplied by the manufacturer, unless for specific strengthening with materials of a similar type (no metal to be used).
- A rear wing may be used on the car, where possible the one supplied with the body, if this is not suitable another one may be used, but maximum width shall be no greater than 300mm, chord shall be a maximum of (including a gurney flap if used) be no more than 65mm, and height shall be no more than 175mm with the car on a flat surface.
- Holes in the body shell shall be limited to fuel tank and needle valve access, a hole of maximum 60mm (6sq.cms.) may be cut into the front windscreen for cooling purposes, also the side windows maybe cut or removed to aid cooling or refuelling.
- An original plastic or foam bumper must be used at all times. It must be fitted on the front of the cars chassis.

THESE CONSTRUCTION/OPERATING RULES HAVE BEEN FORMULATED FOR RACING OF THE GT8 NITRO CLASS AT BRCA SANCTIONED MEETINGS AND MAY DIFFER IN SOME WAYS TO RULES USED IN OTHER COUNTRIES & ORGANISATIONS.

IF YOU DECIDE TO RACE OUTSIDE OF THE UK OR AT A GP YOU MAY NEED TO ALTER YOUR CAR TO SUIT OTHER RULES IN FORCE. THESE RULES ARE COMPOSED ON THE PRETEXT THAT ("IF IT DOESN'T SAY YOU CAN, YOU CANNOT"). IF YOU NEED CLARIFICATION OR INTERPRETATION OF ANY RULE PLEASE ASK THE COMMITTEE.

## GT8 ELECTRIC TECHNICAL RULES

- Batteries: Lithium batteries to be used with a nominal voltage of no more than 15.2volts. Any commercially available battery pack up to 4S. Max charge cut off voltage 16.8volts (4S.) All batteries fitted inside the cars must be the same manufacturer and the same part number. All batteries must be charged in lipo sacks (anybody found not doing this will be asked to leave the meeting on safety grounds).
- Motors: Brushless motors up to and including 2800kva must have a 5mm pinion shaft. Reverse on any speed controller must be disabled.
- Tyres: Rubber tyres only (NO FOAM TYRES) Must be commercially available with manufacture sticker on the inside of the wheel. 17mm hex only on the wheels. Quick change wheels are not allowed. Tyre cleaning allowed (but tyre additive is not allowed).
- Chassis: No carbon chassis allowed. Must be 4WD shaft drive (NO BELTS). No center diff allowed Front and rear diffs must be geared diffs that you add silicone oil to (NO BALL DIFFS ALLOWED). Chassis plate must have min 5 degree kick up at the front (MIN 30MM FRONT GEARBOX/ WISHBONES MUST BE FITTED ONTO THE KICK UP AREA) Weight (min 3500kg).
- Bodyshell: Bodyshell must be commercially available. Rear wing width (MAX 310MM). Wing chord (MAX 79MM). Wing end plates (MAX 40MM X 79MM). Wing height to be no more than 200MM from ground level when chassis plate is on a 30MM block.

## PROCEDURES

- 10th IC Circuit
- Races will be called BRCA 1/10th I.C. Circuit. Controlled practice sessions to be held between 2pm & 5pm on the Saturday. Marshals required.
- A six minute practice run for all competitors before the start of qualification in heat order at Race Director's discretion.



- Where possible four rounds of heats will be run. This will be at the Race Director's discretion. Heats will be of 4 minutes duration with a minimum of two minutes warmup for the 1/10 classes. GT8 Nitro heats will be 5mins duration with a minimum of 2 minutes warmup. GT8 Electric heats will be 5mins duration with a minimum of 1 minute warmup.
- Heats will be started using a rolling, staggered start.
- Cars are assumed to be running before the start in the 'warm-up' period between heats. The drivers will be warned of the start of the race 1 minute and again 30 seconds before the start.
- A car's race time will start the first time that car crosses the timing loop after the start has been signalled. The car's race time must only be started by the car's transponder unless it has not completed a full lap when the race time clock is at 30 seconds, at which point all un-started clocks will start.
- After failure to make the start or on any re-starts during a heat the car must enter the track from the pit lane exit.
- Heats in qualifying and finals can comprise 10 or more cars where the rostrum is large enough. If this produces a 'first heat' with so few cars that marshal provision for the next race is impractical, all heats will be adjusted in size so as to produce an even number of cars in all heats.

## SERIES POINTS

- The Series should consist of 6 rounds with 4 to count. Rounds to be 1 per month between April & September.  
Finals: The winner of the A Final will receive 100 points, 2nd place in the A Final will receive 99 points and so on down to 10th place in the J final who will receive 1 point. All further drivers will receive 1 point. Only drivers who complete at least one lap will be awarded their points for the Final.
- The driver who achieves the fastest time in qualifying (FTD) will be awarded one extra point.
- In the event of a points tie, the winner will be decided on count back. The competitor with the most event wins will be victorious, if this leaves them still tied, the competitors' highest points scores will be compared, then the next highest, then the next etc. until one competitor emerges with a better result. If all results are identical a tie will be declared.
- If finals cannot be run due to extreme weather, points will be awarded on qualifying positions.

## FINALS

- Echelon or Grid starts will be used for all finals in BRCA 1/10th IC Circuit events. The minimum distance between the cars on the grid should be 3 metres.
- Finals in all classes will be A-Z type format with qualifying by FTQ.
- The A final Nitro will be of 30 minutes duration.
- All other Nitro finals will be of 25 minutes duration.
- GT8 Electric Finals will be 2 or 3 6 minute finals with 1 minute warm up. Points will be awarded as follows. 1 point for 1st place and up to 10 points for 10th place. The scores for each final will be added together and the lowest score wins the meeting.
- Cars must cross the finishing line under their own power to be counted.
- Note. The duration of the finals may be subject to variation on the day as decided by the committee members in attendance.
- In addition to Drivers and Marshals, all Mechanics must have a current BRCA License.
- In wet weather conditions the meeting will continue as normal and will not be cancelled unless extreme problems arise.
- All cars are to join the circuit from the Pit Lane at all times, except for the start of the final, which will be from the designated starting grid. If a car fails to start from its designated grid position, then a stop and go penalty will be applied unless car has started from pit lane. Should a car leave the circuit for any reason, and rejoin the track in such a way as to gain an advantage, the competitor will receive a 'stop and go' penalty at the Race Official's discretion.
- All Nitro cars must be re-fuelled behind the Pit Lane Board during Qualifying and Finals at all circuits.

## SAFETY

- All Motor Sport, even Model Car Racing, is potentially dangerous. Competitors MUST consider the safety of Marshals, Spectators, and other drivers at all times. Pay particular attention to the presence of Marshals and pitmen within the track area, particularly during warm-up before the start of a qualifying heat or final.
- Marshals must consider their own safety above the need to retrieve a stranded car. Do not step out into the track without checking it is clear. Take great care when moving to or from your Marshal point between heats. Stay behind any protective shields/fencing provided at your Marshal point unless you need to marshal a car.
- Competitors must take note of safety announcements from the Race Director during the drivers briefing and at other times. Race Control will attempt to warn you if marshals are on the track, but be alert at all times to the possible presence of marshals on the racing line.

- The Race Director or the Safety Officer will stop all racing if lightning is seen in the area. Racing will be suspended until such time that the Safety Officer gives clearance to continue. Any part completed races will be re-run at the discretion of the Race Director.
- Under no circumstances will anyone under the age of 16 years old be allowed into the track area, with the exception of the Pit Lane. Any driver under 16, who has entered the race meeting, MUST provide a substitute marshal. If a driver cannot provide a substitute marshal, then they must report it to the race organiser/Steward.
- All drivers and pit persons must supply and wear a yellow high visibility vests at all times within the track area.

## GENERAL

- All interference claims and any protests must be referred to the Steward. The Race Director, in consultation with the Steward will agree any subsequent action. All direct approaches to the Race Director or Timekeeper will be ignored.
- Any driver claiming interference must switch off and see the Steward WHILE THE RACE IS STILL IN PROGRESS. The Steward will use the following guidelines. To ensure continuity no qualifying heat will be stopped unless the Steward is satisfied that two or more drivers have detectable interference.
- The Driver's Briefing will be held before Timed Practice on the Saturday afternoon. The Steward will aim to provide each competitor with TWO heats free from extraneous interference. The Steward will check interference possibilities with all drivers before the start of Finals and these races will not be stopped unless the Steward and the Race Director are satisfied that on site interference is occurring. A driver claiming interference must switch off and report to the Steward immediately.
- At the discretion of the Race Director, any competitor found with equipment causing on site interference will be disqualified.
- The Steward and Race Director will also monitor driving standards and competitors behaviour. They have the following penalties for use at their discretion; 1 A Verbal warning which will be announced over the PA. 2 Stop and go penalty (in the stop go box), 3 A 5 second Stop and go (in the stop go box), 4 A one lap penalty and or disqualification. A fifth offence the Steward or Race Director will disqualify the driver from the days racing. The Steward or Race Director may disqualify without warning where they considers the infringement or misbehaviour to warrant such a penalty. As a guide line to the drivers the following driving standards are expected: Slower cars are to give way to the faster cars and drivers of the slower cars should call his attention while moving off line. Any deliberate collisions from behind with an on line car at a corner (T-BONING) will be regarded as unacceptable practice.
- Any driver not fulfilling their marshalling obligations during qualifying will be penalised by a 10 second penalty at the race director's discretion. Drivers, who fail to marshal their final without notifying the Race Director, will lose their highest score for the series for the current year. Drivers must arrange for a BRCA licensed member who is a competent person as a substitute if they are unable to marshal for any reason unless the Race Director considers special needs apply.
- Drivers to marshal the heat following the one in which they raced, except for the last heat drivers who will marshal heat one.
- Drivers of the last final will marshal for the first final.
- All other finalists will marshal the final following the one in which they have raced.
- Marshals are to retrieve inoperative cars from the track and leave them for collection by the mechanics only. Where a car stops on the infield then the marshal is to retrieve the car and place it on the outside of the track at the nearest point without crossing the track as appropriate. Mechanics are only allowed to retrieve their cars from the track by walking around the track to the appropriate marshal point. They are not allowed to cross over the track when the race is in progress or during warm up. If a car stops inside the track the marshals will be the only people allowed to retrieve the car and place it on the nearest point on the external part of the track. Any mechanics found crossing the track will have their driver appropriately penalized as felt fit by the Race Director.
- Only two mechanics (one may be the driver) per car are allowed to attend the car in the pit lane at any time. More than two mechanics will cause the driver to lose their fastest time of the day, or receive last place points in their final. Repeated offences will cause the driver to be disqualified from the day's meeting. The only other people allowed in the pits will be officials and BRCA 1/10 IC committee members.
- Where a driver wishes to appeal against a decision made against them, they alone must appeal to the Race Steward within 10 minutes of the end of the last final. An adult may represent any driver under the age of 16. The committee's decision on the day will be final.
- At the completion of each race, a random selection of cars may be scrutineered to check their compliance with the construction rules.
- A BRCA Section Officer or the Race Steward may inspect any entrant's car at any appropriate

time to cover any or all, applicable specifications. It is the driver's responsibility to make sure his/her car is within the specifications at all times.

- Rules must be applied as they are printed in the BRCA Handbook. Where a Section Rule conflicts with BRCA General Rules, the section rule will be removed from the regulations.
- Up to two drivers per heat to do scrutineering and not marshal the next heat after their race. No driver under sixteen to do this task. These Drivers cannot fail a car but must call the Chief Scrutineer or a BRCA Official to make sure the car has failed.
- With the agreement of the Host Club, a liquid of a sugary kind will be sprayed onto the track at the start of the weekend.
- Any entries received after 21:00 on the Tuesday preceding each event will be considered 'on the day' entries and will only be accepted if space is available. 'On the day' entries will incur a £5 surcharge. No entries will be accepted after 'Drivers Briefing' has been called.
- The Committee has the authority to amend any rule during the season if circumstances indicate that the rule is detrimental to the section, with the agreement of the majority of the drivers.

## INTERNATIONAL TEAM SELECTION

- The British team for future European or World Championships is to be selected by the committee. Preference will be given to drivers who have competed in the national series from the previous year.

## RADIO CONTROL EQUIPMENT

- It is the responsibility of ALL drivers to ensure that their equipment does not cause interference to others.
- Drivers must be able to provide a total of at least four alternative frequencies and they must be legal as specified in the BRCA handbook.
- Under no circumstances shall a transmitter be taken on to the track.
- The Race Director must approve all frequency changes.
- Where frequencies conflict in the finals, the fastest qualifier shall choose providing it is possible for the slower qualifiers to change to the available frequency.



**RC Racing Europe**  
www.rcracingeurope.co.uk

01377 258585



**THE HOME OF:**

- Capricorn Cars
- ONE Engines
- ZooRacing BodysHELLs
- Speedwurx Racing Fuel







**Multiple National  
Championship  
Winning Products and  
Support!**

Name Nom 氏名	Date Datum Date 日付	Track Strecke Piste サーキット	Event Veranstaltung Événement イベント	Track Condition Streckenstatus Conditions de piste 路面状況
-------------------	-----------------------------	------------------------------------	---	--

**Front**  
Vorne  
Avant  
フロント

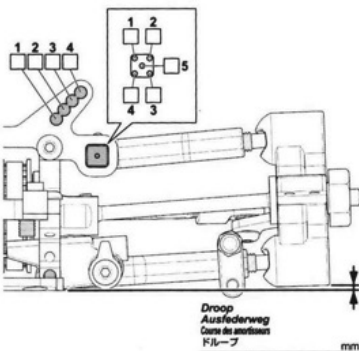

**Front Diff**  
Vorderes Differential  
Diff. avant  
フロントデフ

Diff #  
Spool  
One-way

**Wheel Hubs**  
Radmitnehmer  
Moyeu  
ホイールハブ

4 mm (#72044)  
5 mm (STD)  
6 mm (72036)

**Tread**  
Profil  
Bande de roulement  
全幅

mm

**Ride Height**  
Bodenfreiheit  
Garde au sol  
車高

mm

**Shocks**  
Dämpfer  
Amortisseurs  
ショック

**Oil wt.**  
Ölviskosität  
Grade huile  
オイル番号

**Piston**  
Kolbenplatte  
Piston  
ピストン

mm

1 2 3 Holes

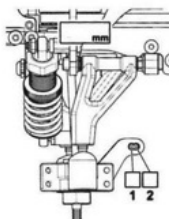

**Camber Angle**  
Sturz  
Angle de carrossage  
キャンバー角

0G  
1G

**Toe Angle**  
Vorspur  
Angle de placement  
トー角

.

**Sway Bar**  
Stabilisator  
Barre antiroulis  
スタビライザー

mm

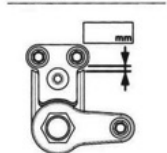

**Bladder**  
Dämpfmembran  
Coupelle  
フラダラー

**Spring**  
Federn  
Ressorts  
スプリング

**Notes**  
Notizen  
Notes  
メモ

**Rear**  
Hinten  
Arrière  
リア

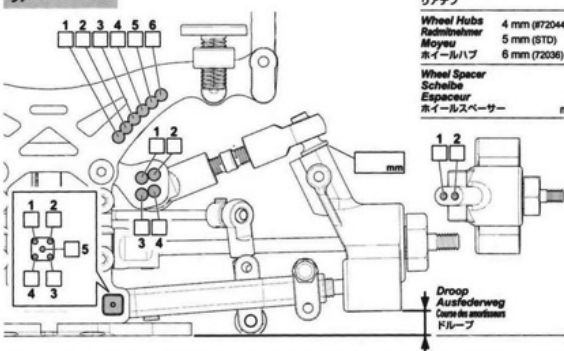

**Rear Diff**  
Hinteres Differential  
Differential arrière  
リアデフ

Wheel Hubs  
Radmitnehmer  
Moyeu  
ホイールハブ

4 mm (#72044)  
5 mm (STD)  
6 mm (72036)

**Tread**  
Profil  
Bande de roulement  
全幅

mm

**Ride Height**  
Bodenfreiheit  
Garde au sol  
車高

mm

**Shocks**  
Dämpfer  
Amortisseurs  
ショック

**Oil wt.**  
Ölviskosität  
Grade huile  
オイル番号

**Piston**  
Kolbenplatte  
Piston  
ピストン

mm

1 2 3 Holes

**Wheel Spacer**  
Schelbe  
Espaceur  
ホイールスペーサー

mm

**Camber Angle**  
Sturz  
Angle de carrossage  
キャンバー角

0G  
1G

**Toe Angle**  
Vorspur  
Angle de placement  
トー角

.

**Sway Bar**  
Stabilisator  
Barre antiroulis  
スタビライザー

1.7 1.9  
2.1 2.3

mm

**Rear Wheel Base**  
R#  
リアホイールベース

Short  
Long

**Bladder**  
Dämpfmembran  
Coupelle  
フラダラー

**Spring**  
Federn  
Ressorts  
スプリング

**Notes**  
Notizen  
Notes  
メモ

**Clutch Shoes**  
Kupplungsbacke  
Masselots d'embrayage  
クラッチシュー

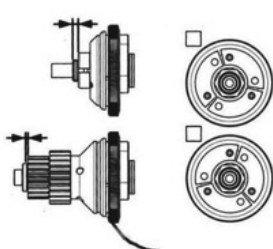

**Clutch Spring**  
Kupplungsfeder  
Ressort d'embrayage  
クラッチスプリング

**Adjust Nut**  
Einstellmutter  
Écrou de réglage  
アジャストナット

mm

**Gap**  
Lücke  
Espacement  
クリアランス

mm

**Notes**  
Notizen  
Notes  
メモ

**Engine**  
Motor  
Moteur  
エンジン

**Spur gear**  
Hauptzahnrad  
Couronne  
スパーギア

**Pinion gear**  
Ritzel  
Pignon  
ピニオンギア

**Body**  
Karosserie  
Carrosserie  
ボディ

**Tires**  
Reifen  
Pneus  
タイヤ

Front Vorne Avant フロント	Rear Hinten Arrière リア
---------------------------------	---------------------------------

**Brand**  
Hersteller  
Marque  
製用タイヤ

**Compound**  
Mischung  
Gomme  
コンパウンド

**Tire Diameter**  
Reifenmesser  
Diamètre es pneu  
タイヤ径

mm

mm

**Notes**  
Notizen  
Notes  
メモ

**elite racing**



# RACE NUMBERS

OUR RANGE OF RACE NUMBERS  
FOR 2022 ARE NOW AVAILABLE

**50mm**  
BLACK NUMBERS  
ON WHITE

#1-10  
**£30**

ROLLS OF 100 = 1000 NUMBERS

#1-6  
**£20**

ROLLS OF 100 = 600 NUMBERS

**NEW**  
**65mm**  
BLACK NUMBERS  
ON YELLOW

#1-14  
**£45**

ROLLS OF 100 = 1400 NUMBERS

**BRCA**  
BRITISH RADIO CAR ASSOCIATION

Order via [www.brca.org](http://www.brca.org)

Prices include postage, allow 3-4 days for delivery.

For Assistance go to [www.brca.org/contact](http://www.brca.org/contact)

ON YOUR MARKS,

# GET SET, SUBSCRIBE!

GET RACER DELIVERED THROUGH YOUR DOOR AND SAVE UP TO

**47%** + A FREE GIFT

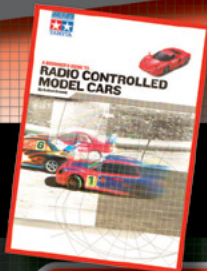

**SUBSCRIBE TODAY - GET 12 ISSUES FOR £27  
& GET THE BEGINNERS GUIDE TO RC CARS WORTH £11.95 FREE!!!**

[www.rcracer.com](http://www.rcracer.com)



Follow us on Facebook  
[facebook.com/rcracermagazine](https://facebook.com/rcracermagazine)

Follow us on Twitter

[@rcracermagazine](https://twitter.com/rcracermagazine)



01525 222573



[www.doolittlemedia.com](http://www.doolittlemedia.com)



[enquiries@doolittlemedia.com](mailto:enquiries@doolittlemedia.com)



Image courtesy of [www.neo-buggy.net](http://www.neo-buggy.net)

Available on the iPhone  
App Store

Google play

